

**SEN**  
International

真空泵 压缩机  
vacuum pump/compressor

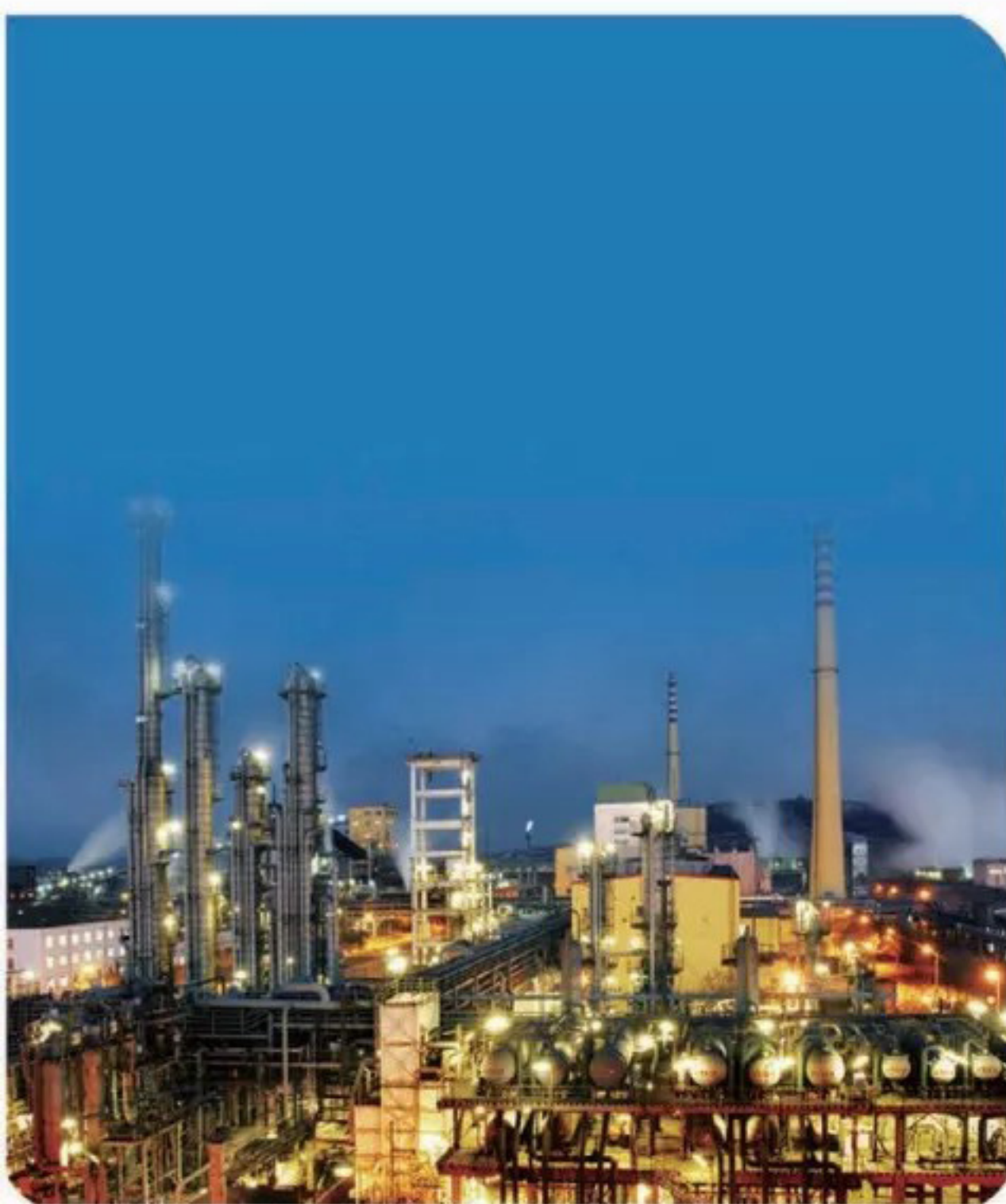

**SEN International**

VACUUM PUMP SOLUTIONS

# 目录 Content

- **概述**  
General information P03
- **2BE 系列水环真空泵及压缩机**  
2BE series liquid ring vacuum pumps and compressors P08
- **2BV 系列真空泵及压缩机**  
2BV series liquid ring vacuum pumps P32
- **DLV 系列双级水环真空泵**  
CL series cone liquid ring vacuum pumps P40
- **LG 型等螺距螺杆真空泵系列**  
LG type equal pitch screw vacuum pump series P46
- **LGB 型变螺距螺杆真空泵系列**  
LGB type variable pitch screw vacuum pump series P47
- **罗茨螺杆真空机组**  
Roots screw vacuum unit P48
- **SY/2SY 系列水环压缩机**  
SY/2SY series liquid ring compressors P51

- **WL/WLW 系列立式 ( 无油 ) 往复真空泵**  
WL/WLW series vertical reciprocating vacuum pumps(oil-free) **P54**

- **ZIP 系列罗茨泵**  
ZJP series booster vacuum pumps **P55**

- **JZJ2B/2S 系列水环罗茨机组**  
JZJ2B/2S series booster --liquid ring vacuum systems **P56**

- **SK/2SK 系列水环真空泵及压缩机**  
SK/2SK series liquid ring vacuum pumps and compressors **P59**

- **真空 / 压缩系统及应用**  
Vacum /Compressor system and applications **P60**

- **应用行业**  
Industrial application **P64**

- **技术资料**  
Technical data **P66**

## ● 生产控制过程 production control process

一路走来，SEN International 始终坚信中国制造的力量，将技术创新和对自己的严格要求贯穿于每一个生产环节。每一台真空产品从设计、选型到生产加工的各个步骤，都倾注了精益求精、精进制作的态度和信念。



Along the way, SEN International has always believed in the power of Chinese manufacturing, and carried technological innovation and strict self-standards through every production step. From design and selection to production and processing, each vacuum product reflects a pursuit of excellence and refined manufacturing.

## ● 测试平台 Test Platform

● 我公司测试中心是与山东省农业机械研究所共同设计的，涵盖水环式真空泵、水泵、潜水泵等多品种产品的检测平台。

Our company's testing center is jointly designed with Shandong Agricultural Machinery Research Institute, covering a testing platform for various products such as water-ring vacuum pumps, water pumps, and submersible pumps.

- 6KV 1500KW 的变压器
- 50/10T 大型双梁吊车
- 全电脑测试终端
- 800M3 大型工作液平台
- 确保所有大型、特大型水环式真空泵及压缩机的配电要求
- 确保大型、特大型水环式真空泵及压缩机的组装和吊运
- 实时性能曲线、电流、转速、功率等参数的显示和记录
- 确保实际检测运行时水环泵尤其是特大型水环泵工作液的正常供给并尽可能保持工作液的标准没讲温度

### Highlights:

6KV,1 500KW transformer: ensure enough power distribution for all kinds of large and extra large pumps and compressors.

50/10T double beam crane: for the assemble and lifting of all large and extra-large pumps and compressors.

Complete computer test terminal: for record and display of real time performance curve,current, speed, power and other parameters.

800m3large working solution platform: supply regular amount of working liquid and keep its temperature.



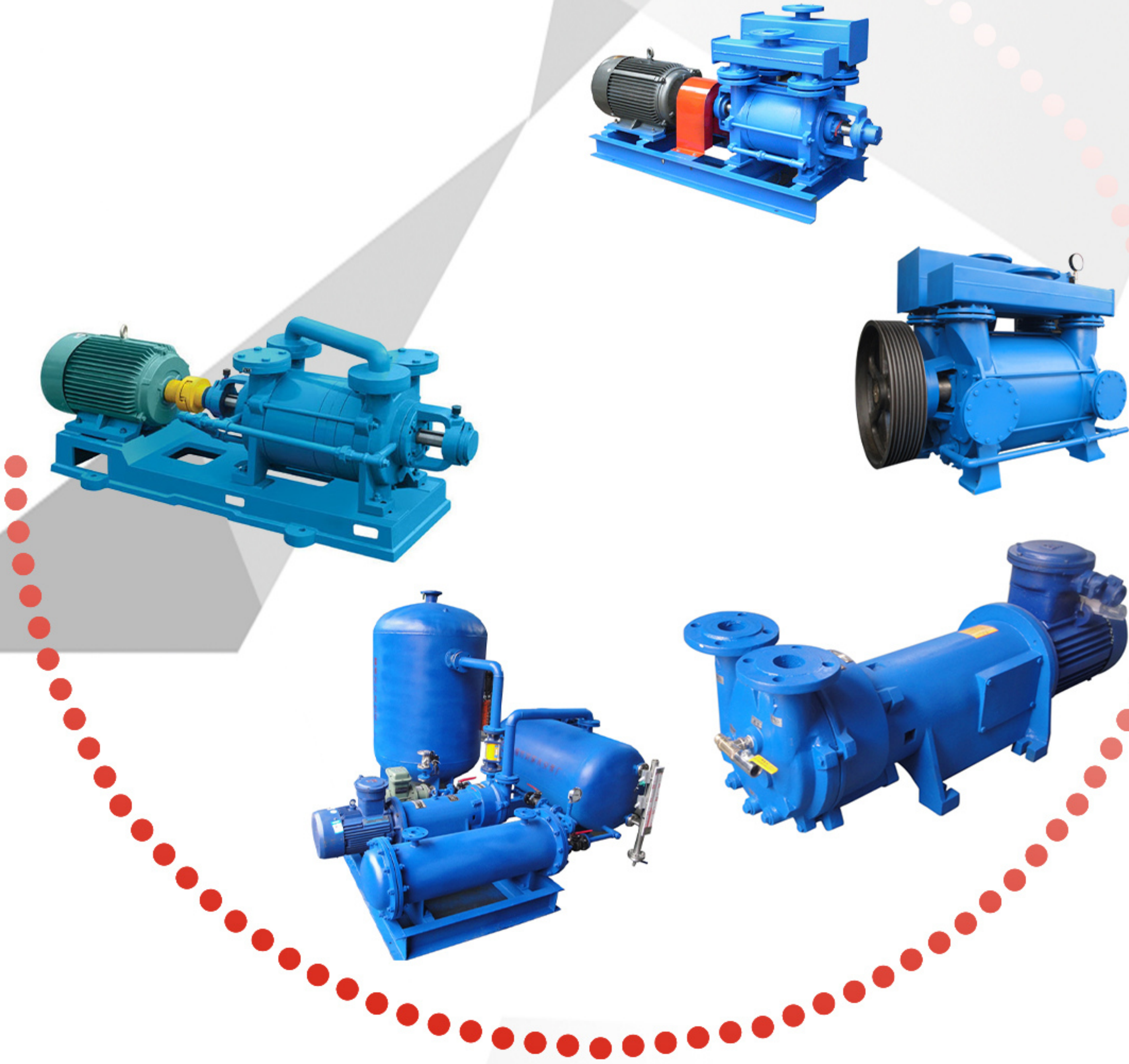

## ● 特材应用

Application of Special Material

● 公司产品多年来在化工方面的应用，使我们积累了丰富的材料使用经验。其中包括：过流件不锈钢的应用，特殊件镀镍、高分子喷涂和全钛材的成功应用。在循环介质含有强酸强碱、易燃易爆、有毒有害的条件下，我们的产品能够确保工作更平稳，运行更可靠，寿命更长久。

The company's products have been used in chemical industry for many years, so that we have accumulated rich experience in the use of materials. These include: the application of stainless steel for overcurrent parts, the successful application of nickel plating for special parts, polymer spraying and all-titanium materials. Under the condition that the circulating medium contains strong acid and alkali, flammable, explosive, toxic and harmful, our products can ensure smoother operation, more reliable operation and longer life.



## ● 气体与液体的组合 Combination of Gas and Liquid



全 304 不锈钢机组  
All 304 stainless steel unit

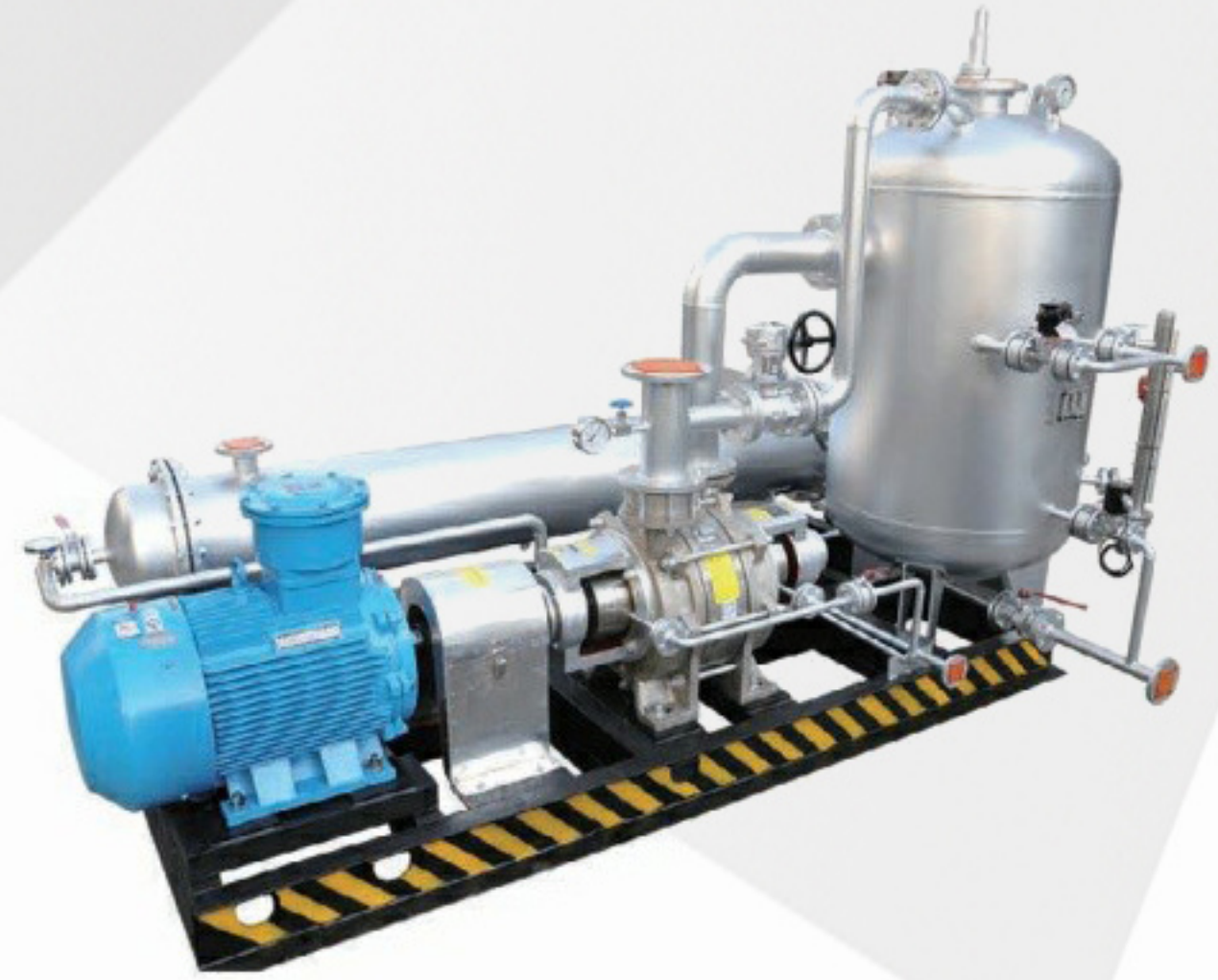

双相不锈钢高压液环机组  
Dual phase stainless steel & High pressure compressor unit

### ● [以水做运行介质]

空气

H<sub>2</sub>, N<sub>2</sub>, O<sub>2</sub>, CO, CO<sub>2</sub>, NO<sub>x</sub>, H<sub>2</sub>S, SO<sub>2</sub>, NH<sub>3</sub> 等  
碳化氢族, CH<sub>4</sub>, C<sub>2</sub>H<sub>6</sub> 等烃族, C<sub>2</sub>H<sub>4</sub>, C<sub>3</sub>H<sub>6</sub> 等烯  
族, C<sub>2</sub>H<sub>2</sub>, 汽油等

聚乙烯单体 (VCM, CH<sub>2</sub>CHCl) 回收压缩城市燃气, 消  
化气, 各种混合气

[水以外做运行液]

98% 浓硫酸—干 Cl<sub>2</sub>, 干 HCl 适合气体的溶剂 (以吸  
入负压为多) 为运行液, 如丙酮、EDC (二氯乙烯)、  
苯 MEK、MIBK、环己烷、甲醇、乙酸等

凝缩性成分的液体

关联流程出现的液体

### ● [use water as the running medium]

Air

H<sub>2</sub>, N<sub>2</sub>, O<sub>2</sub>, CO, CO<sub>2</sub>, NO<sub>x</sub>, H<sub>2</sub>S, SO<sub>2</sub>, NH<sub>3</sub>, etc.  
Hydrocarbons, hydrocarbons such as CH<sub>4</sub>,  
C<sub>2</sub>H<sub>6</sub>, olefins such as C<sub>2</sub>H<sub>4</sub>, C<sub>3</sub>H<sub>6</sub>, C<sub>2</sub>H<sub>2</sub>, gasoline, etc.

Polyethylene monomer (VCM, CH<sub>2</sub>CHCl) recovery  
compressed city gas, digested gas, various mixed gas  
[Running fluid other than water]

98% concentrated sulfuric acid—dry Cl<sub>2</sub>, dry HCl suitable  
for gas solvent (inhalation pressure negative pressure is  
more) as running fluid, such as acetone, EDC (ethylene  
dichloride), benzene MEK, MIBK, cyclohexane, methanol,  
acetic acid, etc.

Liquid with condensable ingredients

Liquids appearing in associated processes

- 我公司建有市级耐腐蚀真空设备研究所, 拥有企业技术研发中心。金属材料研究, 喷焊技术的推广应用, 使铸造合金、耐磨陶瓷涂层等新材料。新工艺不断的满足于耐磨、耐腐蚀、高强度、高寿命特殊用泵的要求。制造工艺、理化检验、计量测试现代化质量控制手段, 保证了我们的产品向世界先进水平迈进!

Our company has a municipal-level corrosion-resistant vacuum equipment research institute and an enterprise technology research and development center. The research of metal materials and the popularization and application of spray welding technology make new materials such as cast alloys and wear-resistant ceramic coatings. The new technology constantly meets the requirements of special pumps with wear resistance, corrosion resistance, high strength and long life. The modern quality control methods of manufacturing technology, physical and chemical inspection, and measurement testing ensure that our products will advance to the world's advanced level!

## ● 2BE1 系列水环式真空泵及压缩机

2BE1 Series Liquid Ring Vacuum Pumps and Compressors

● 2BE 系列水环真空泵及压缩机，是我厂在多年科研成果和生产经验的基础上，结合国际同类产品先进技术，研制开发的高效节能产品。通常用于抽吸不含固体颗粒，不溶于水。无腐蚀性的体。以便在密闭容器中形成真空和压力。通过改变过流件材料。亦可用于抽吸腐蚀气体或以腐蚀性液体做工作液。广泛用于造纸、化工、石化、轻工、制药，食品，冶金。建材、石器、洗煤。选矿、化肥等行业。

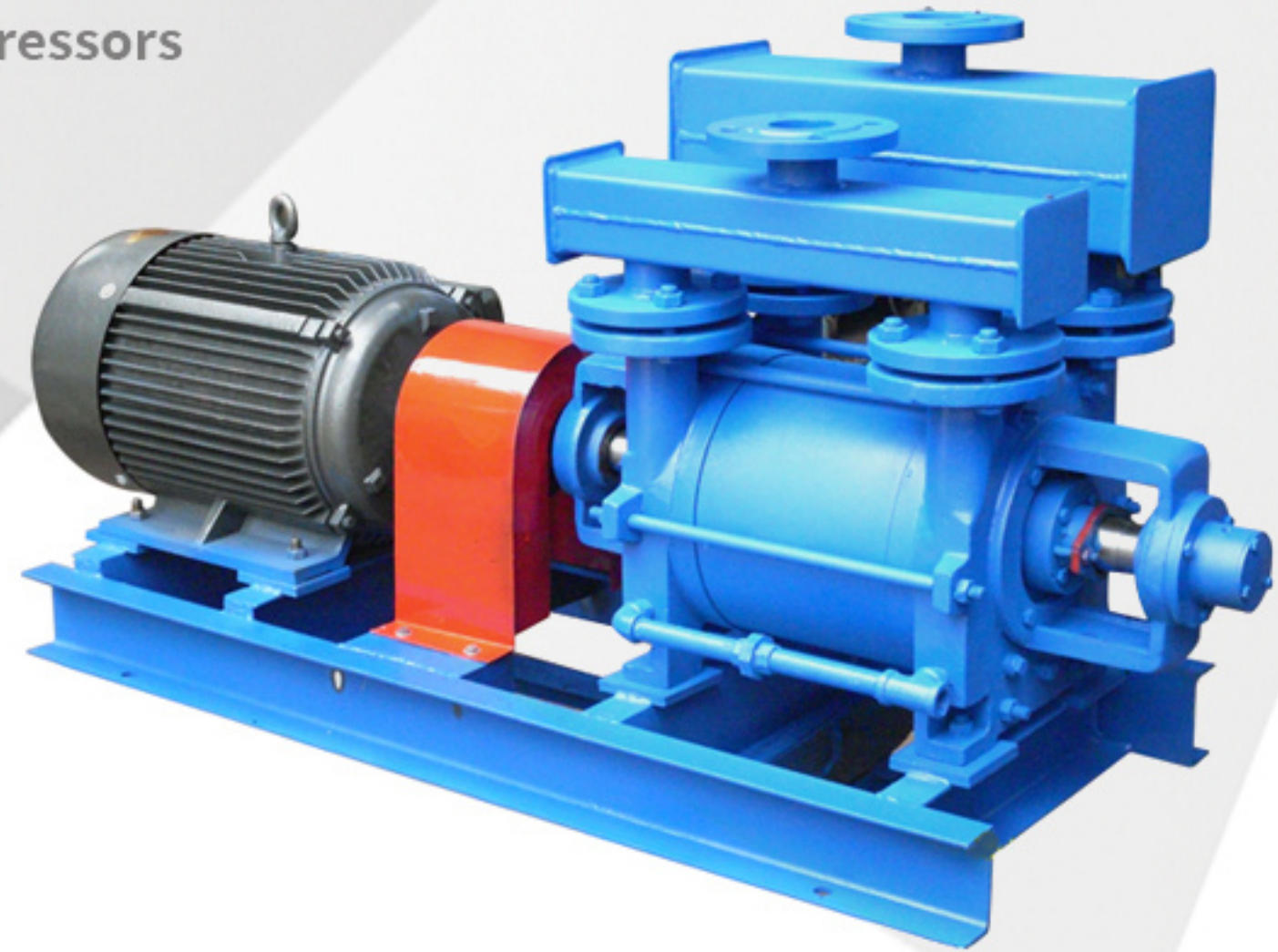

2BE series water ring vacuum pumps and compressors are high-efficiency and energy-saving products developed by our factory on the basis of years of scientific research achievements and production experience, combined with the advanced technology of similar international products. It is often used for suction and does not contain solid particles and is insoluble in water. Non-corrosive body. in order to create a vacuum and pressure in a closed container. By changing the material of the overcurrent. It can also be used to pump corrosive gas or use corrosive liquid as working fluid. Widely used in paper, chemical, petrochemical, light industry, pharmaceutical, food, metallurgy. Building materials, stone tools, coal washing. Mineral processing, fertilizer and other industries.

● 2BE 系列泵的型号以 8 个位的文字 ( 字母 ) 和数字组合表示，标记如下：

2BE1/3--<1><2><3>--<4>

其中：2BE1 为单级水环真空泵系列名称，1 代表 2BE 高真空系列，3 代表大气量低真空系列；

<1> <2> 表示叶轮名义半径 cm

<3> 表示叶轮名义宽径比代号，具体为：1--B(宽)/D(直径)=0.5；2--B/D=0.75；3--B/D=1；5--B/D=1.2；

<4> 表示最低吸入压力代号，具体：0-- 代表极限真空为 33hpa；1-- 代表极限真空为 160hpa；

型号示例："2BE1-403-0" 为叶轮名义直径 800mm，宽径比 1，最低收入绝对压力可达 33hPa 的单级水环真空泵，也可记作：2BE1-403 ( 因为 2BE1 系列极限真空就是 33hpa,2BE3 极限真空 160hpa，因此 <4> 此项一般忽略不加标注 )

The model of the 2BE series pump is represented by a combination of 8-digit text (letters) and numbers, marked as follows:

2BE1/3--<1><2><3>--<4>

Among them: 2BE1 is the name of the single-stage water ring vacuum pump series, 1 represents the 2BE high vacuum series, 3 represents the atmospheric volume low vacuum series;

<1> <2> Indicates the nominal radius of the impeller in cm

<3> Indicates the impeller nominal width-diameter ratio code, specifically: 1--B (width)/D (diameter) =0.5;

2--B/D=0.75;3--B/D=1;5-- B/D=1.2;

<4> Indicates the minimum suction pressure code, specifically: 0--represents the ultimate vacuum of 33hpa; 1--represents the ultimate vacuum of 160hpa;

Model example: "2BE1-403-0" is a single-stage water ring vacuum pump with a nominal impeller diameter of 800mm, an aspect ratio of 1, and a minimum income absolute pressure of 33hPa. It can also be recorded as: 2BE1-403 (because the 2BE1 series ultimate vacuum is 33hpa, 2BE3 ultimate vacuum is 160hpa, so <4> this item is generally ignored and not marked)

## ● 2BE3 系列水环式真空泵及压缩机 2BE3 Series Liquid Ring Vacuum Pumps and Compressors

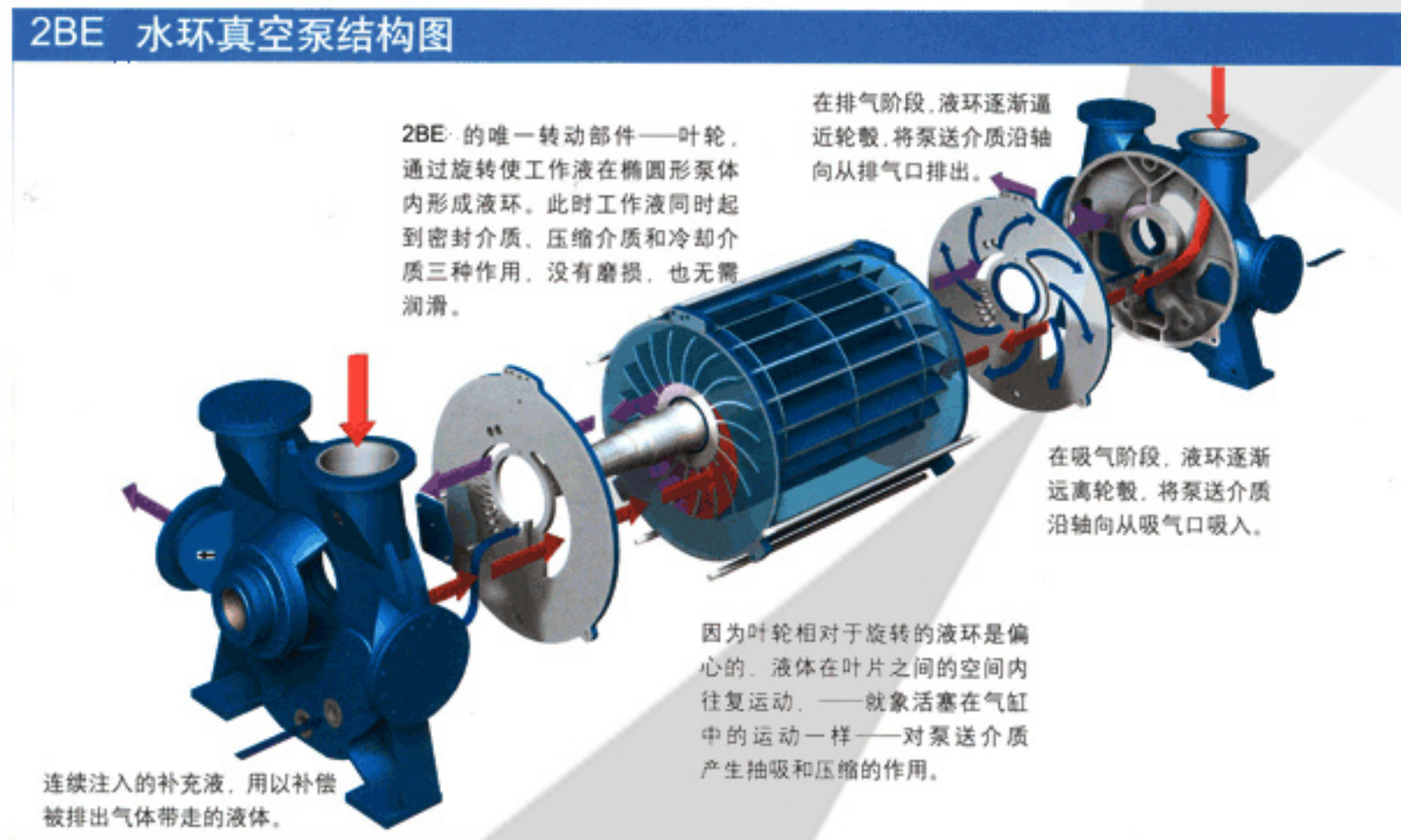

- 2BE3 系列较 2BE1 系列而言，不同点为：(1) 气量明显增大，真空度有所降低，适合于煤矿瓦斯抽放、化工厂变压吸附等大量工作场合；(2) 轴承由圆柱滚珠轴承改为双列圆锥滚子轴承，轴承承载能力增大，寿命提高；(3) 泵体与分配盘的定位地连接由“止口定位”改为“一面两销”，由定位销确保叶轮与泵体的径向间隙；(4) 泵盖除了顶部设进排口外，侧端也设计了进排口位置。如选择顶部进排口，则用盲盖闷死侧端进排气口，增加了安装选择余地。(5) 2BE3 系列的泵由于体积大，吸气量大，能耗功率也同时加大，因此电机可选为高压电机，传动一般推荐减速机传动，皮带传动最高到 50/52 型号，60 及以上泵应选用减速机传动。(6) 2BE3 系列泵体内增加偏心隔板，可同叶轮中板配合将泵体分成两个腔。同时启用侧法兰进排气口，可使一台泵满足需要两个不同压力点的行业。如造纸。

Compared with the 2BE1 series, the 2BE3 series has the following differences: (1) The gas volume is significantly increased, and the vacuum degree is reduced, so it is suitable for a large number of working occasions such as coal mine gas drainage, chemical plant pressure swing adsorption, etc.; (2) The bearings are made of cylindrical balls. The bearing is changed to double-row tapered roller bearing, the bearing capacity is increased, and the service life is improved; (3) The positioning connection between the pump body and the distribution plate is changed from "port positioning" to "two pins on one side", and the positioning pin ensures the impeller Radial clearance with the pump body; (4) In addition to the inlet and outlet at the top of the pump cover, the position of the inlet and outlet is also designed at the side end. If the top intake and exhaust is selected, the side intake and exhaust ports are smothered with a blind cover, which increases the installation options. (5) The 2BE3 series pumps are large in size, large in suction volume, and high in energy consumption and power. Therefore, the motor can be selected as a high-voltage motor. The transmission generally recommends a reducer drive, and the belt drive is up to 50/52 models, 60 and The above pumps should be driven by a reducer. (6) 2BE3 series pump body is added with an eccentric baffle plate, which can cooperate with the impeller middle plate to divide the pump body into two cavities. At the same time, the side flange inlet and exhaust ports are enabled, so that one pump can meet the needs of industries that require two different pressure points. such as papermaking.

## 2BE1-102/103/152/153/202/203/252/253剖面结构图 Sectional Drawing

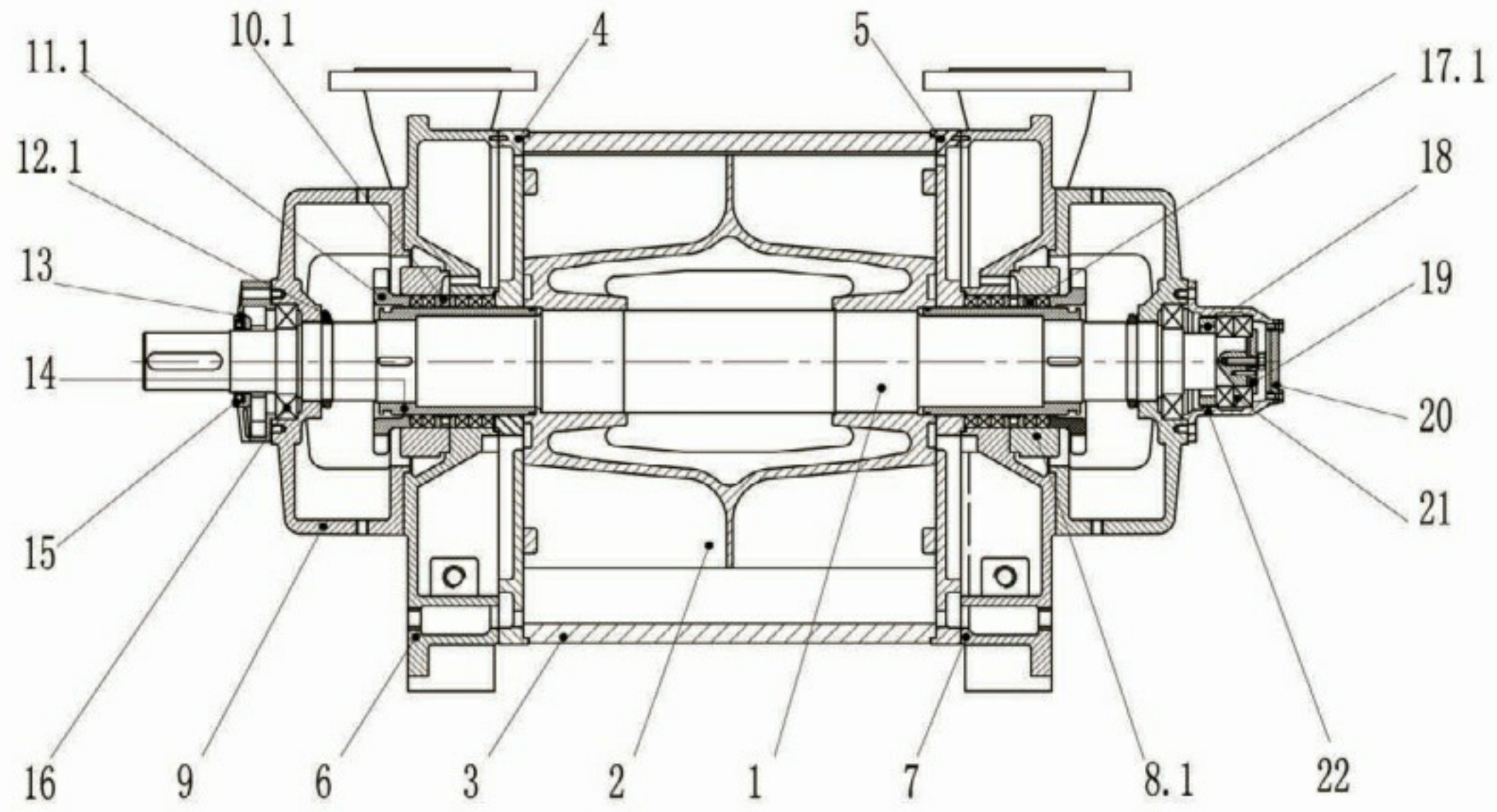

序号 No.	名称 Name	序号 No.	名称 Name	序号 No.	名称 Name	序号 No.	名称 Name
1	主轴 shaft	2	叶轮 impeller	3	泵体 casing	4	前圆盘 front port plate
5	后圆盘 back port plate	6	前泵盖 front end shield	7	后泵盖 back end shield	8.1	填料函 packing box
9	轴承架 bearing bracket	10.1	填料环 packing ring	11.1	填料压盖 packing cover	12.1	挡水圈 waterproof ring
13	前轴承压盖 bearing cap	14	轴套 shaft sleeve	15	骨架油封 framework oil seal	16	支撑轴承 axial bearing
17.1	填料 packing	18	后轴承压盖 bearing cap	19	轴压盖 shaft gland	20	轴承挡盖 bearing cap
21	定位轴承 locating bearing	22	后轴承座 back bearing pedestal	11.2	机封压盖 mechanical seal gland	17.2	机械密封 mechanical seal

## 2BE1-303/305/353/355/403/405剖面结构图 Sectional Drawing

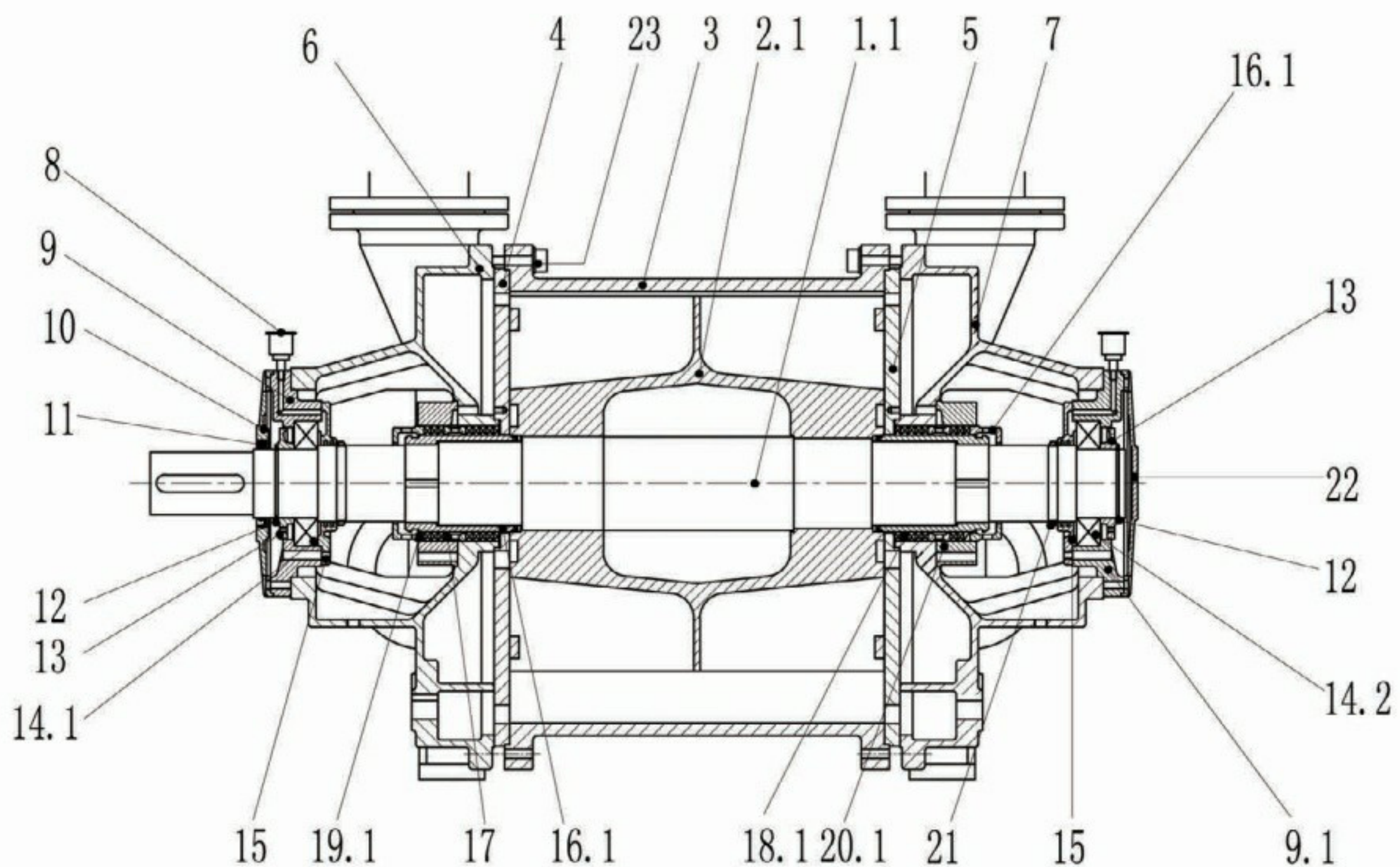

序号 No.	名称	Name	序号 No.	名称	Name
1	主轴	shaft	2	叶轮	impeller
3	泵体	casing	4	前圆盘	front port plate
5	后圆盘	back port plate	6	前泵盖	front end shield
7	后泵盖	back end shield	8	油杯	oil cup
9	轴承架	bearing bracket	10	前轴承压盖	front bearing cap
11	骨架油封	framework oil seal	12	弹性挡圈	circlip
13	挡油盘	oil retaining disc	14.1	前轴承	front bearing
14.2	后轴承	back bearing	15	轴承压盖	bearing cover
16	轴套	shaft sleeve	17	填料环	packing ring
18.1	填料	packing	19.1	填料压盖	packing cover
20.1	填料函	packing box	21	挡水圈	waterproof ring
22	后轴承压盖	back bearing cap	23	螺栓	bolts
18.2	机械密封	mechanical seal	19.2	机封压盖	mechanical seal gland

## 2BE3 系列剖面结构图 Sectional Drawing

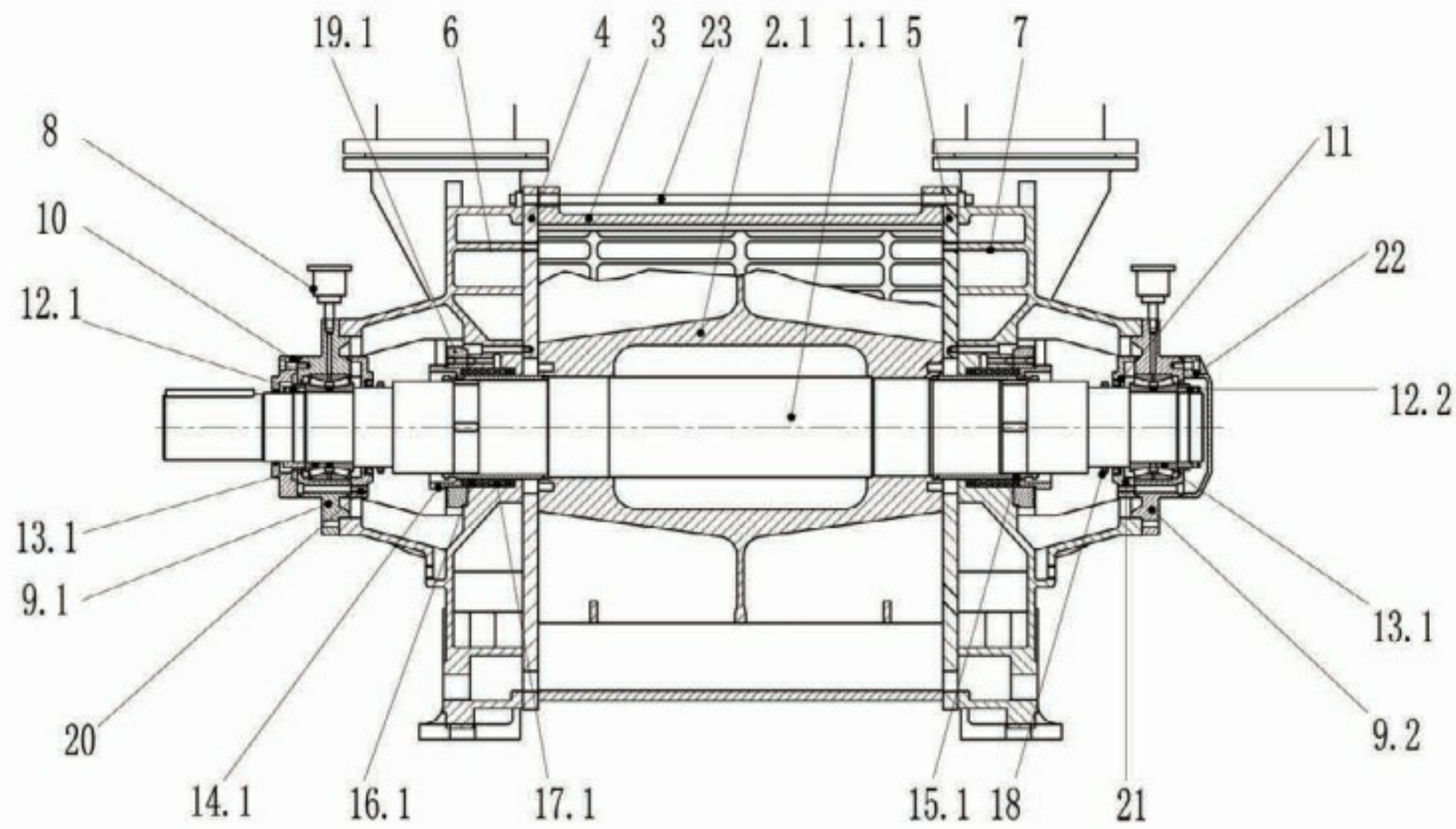

序号 No.	名称	Name	序号 No.	名称	Name
1	主轴	shaft	2	叶轮	impeller
3	泵体	casing	4	前圆盘	front port plate
5	后圆盘	back port plate	6	前泵盖	front end shield
7	后泵盖	back end shield	8	油杯	oil cup
9.1	前轴承座	front bearing bracket	9.2	后轴承座	back bearing bracket
10	前轴承压盖	front bearing cap	11	骨架油封	framework oil seal
12.1	前锁紧螺母	fore lock nut	12.2	后锁紧螺母	back lock nut
13	轴承	bearing	14	轴承压盖	bearing cover
15	轴套	shaft sleeve	16.1	填料	packing
17.1	填料环	packing ring	18	挡水圈	waterproof ring
19.1	填料函	packing box	20	前轴承挡盖	front bearing cover
21	后轴承挡盖	back bearing cover	22	后轴承压盖	back bearing cap
23	螺栓	bolts	16.2	机械密封	mechanical seal
19.2	机封压盖	mechanical seal gland			

2BE1 系列技术性能表/2BE1 Technical Parameters

型号 Model	转速 Speed (r/min)	轴功率 Shaft power (kW)	配用电机 Motor Power (KW)	极限真空度 Limit vacuum	最大抽气速率 Suction capacity		泵头重 Weight excluding motor(kg)
					m <sup>3</sup> /h	m <sup>3</sup> /min	
2BE1-102	1450 (直联)	6.0	Y132M-4-7.5	33hpa (-0.097Mpa)	246	4.1	110
	1750 (皮带)	8.0	Y160M-4-11		290	4.8	
2BE1-103	1450 (直联)	8.2	Y160M-4-11	33hpa (-0.097Mpa)	340	5.7	125
	1750 (皮带)	11.1	Y160L-4-15		412	6.9	
2BE1-152	1450 (直联)	12.5	Y160L-4-15	33hpa (-0.097Mpa)	450	7.5	175
	1625 (皮带)	15.0	Y180M-4-18.5		510	8.5	
	1750 (皮带)	17.2	Y180L-4-22		535	8.9	
2BE1-153	1450 (直联)	16.3	Y180M-4-18.5	33hpa (-0.097Mpa)	600	10.0	200
	1100 (皮带)	10.6	Y160L-4-15		445	7.4	
	1300 (皮带)	13.4	Y180M-4-18.5		535	8.9	
	1620 (皮带)	19.6	Y180L-4-22		648	10.8	
	1750 (皮带)	22.3	Y200L-4-30		700	11.7	
2BE1-202	980 (直联)	18.2	Y200L2-6-22	33hpa (-0.097Mpa)	750	12.5	460
	790 (皮带)	13.4	Y180M-4-18.5		590	9.8	
	880 (皮带)	16.3	Y180M-4-18.5		670	11.2	
	1100 (皮带)	23.8	Y200L-4-30		860	14.3	
	1170 (皮带)	25.7	Y200L-4-30		888	14.8	
	1300 (皮带)	30	Y225S-4-37		950	15.8	
2BE1-203	980 (直联)	29.5	Y250M-6-37	33hpa (-0.097Mpa)	1080	18	530
	790 (皮带)	21.2	Y200L-4-30		870	14.5	
	880 (皮带)	24.8	Y200L-4-30		980	16.3	
	1100 (皮带)	34	Y225M-4-45		1210	20.2	
	1170 (皮带)	38	Y225M-4-45		1320	22.0	
	1300 (皮带)	42	Y250M-4-55		1390	23.2	
2BE1-252	740 (直联)	38	Y280M-8-45	33hpa (-0.097Mpa)	1700	28.3	870
	590 (皮带)	24	Y200L-4-30		1200	20.0	
	660 (皮带)	31.8	Y225S-4-37		1500	25.0	
	830 (皮带)	45	Y250M-4-55		1770	29.5	
	885 (皮带)	54	Y280S-4-75		2000	33.3	
	938 (皮带)	60	Y280S-4-75		2100	35.0	
2BE1-253	740 (直联)	54	Y315M-8-75	33hpa (-0.097Mpa)	2450	40.8	930
	565 (皮带)	37.2	Y225M-4-45		1690	28.2	
	660 (皮带)	45	Y250M-4-55		2100	35	
	740 (皮带)	50.8	Y280S-4-75		2340	39	
	792 (皮带)	60	Y280S-4-75		2560	42.7	
	820 (皮带)	68	Y280M-4-75		2640	44	
	880 (皮带)	75.1	Y280M-4-90		2780	46.3	
	940 (皮带)	88	Y315S-4-110		3050	50.8	
2BE1-303	740 (直联)	98	Y315L2-8-110	33hpa	4000	66.7	1700

2BE1 系列技术性能表/2BE1 Technical Parameters

型号 Model	转速 Speed (r/min)	轴功率 Shaft power (kW)	配用电机 Motor Power (KW)	极限真空度 Limit vacuum	最大抽气速率 Suction capacity		泵头重 Weight excluding motor(kg)
					m <sup>3</sup> /h	m <sup>3</sup> /min	
2BE1-303	590 (直联)	65.5	Y315L2-10-75	(-0.097Mpa)	3200	53.3	
	466 (皮带)	48	Y250M-4-55		2520	42	
	530 (皮带)	58	Y280S-4-75		2820	47	
	583 (皮带)	64	Y280S-4-75		3100	51.7	
	660 (皮带)	79.8	Y280M-4-90		3550	59.2	
	740 (皮带)	96	Y315S-4-110		3840	64	
2BE1-305	740 (直联)	108	Y355M1-8-132	33hpa (-0.097Mpa)	4520	75.3	1820
	590 (直联)	70	Y355M1-10-90		3750	62.5	
	490 (皮带)	55	Y280S-4-75		3150	52.5	
	530 (皮带)	61	Y280S-4-75		3380	56.4	
	583 (皮带)	68	Y280M-4-90		3700	61.2	
	660 (皮带)	90	Y315S-4-110		4090	68.1	
	740 (皮带)	110	Y315M-4-132		4550	75.8	
2BE1-353	590 (直联)	121	Y355L2-10-160	33hpa (-0.097Mpa)	5300	88.3	1950
	390 (皮带)	63	Y280S-4-75		3580	59.7	
	425 (皮带)	71	Y280M-4-90		3700	61.7	
	460 (皮带)	78	Y280M-4-90		4100	68.3	
	520 (皮带)	93	Y315S-4-110		4620	77.0	
	585 (皮带)	113	Y315M-4-132		5200	86.7	
	620 (皮带)	133	Y315L1-4-160		5500	91.7	
	660 (皮带)	152	Y315L2-4-185		5850	97.5	
2BE1-355	590 (直联)	136	Y355L2-10-160	33hpa (-0.097Mpa)	5700	95	2200
	390 (皮带)	75	Y280M-4-90		4180	69.7	
	430 (皮带)	86	Y315S-4-110		4260	71	
	464 (皮带)	90	Y315S-4-110		4850	80.8	
	523 (皮带)	113	Y315M-4-132		5230	87.1	
	590 (皮带)	136	Y315L1-4-160		6000	100	
	660 (皮带)	167	Y315L2-4-185		6510	108	
2BE1-403	330 (皮带)	98	Y315M-4-132	33hpa (-0.097Mpa)	4860	81	3750
	372 (皮带)	110	Y315M-4-132		5400	90	
	420 (皮带)	131	Y315L1-4-160		6470	107.8	
	472 (皮带)	160	Y315L2-4-200		7380	123.0	
	530 (皮带)	213	Y355M2-4-250		8100	135.0	
2BE1-405	330 (皮带)	100	Y315M-4-132	33hpa (-0.097Mpa)	6000	100.0	3900
	372 (皮带)	118	Y315L1-4-160		6700	111.7	
	420 (皮带)	140	Y315L2-4-185		7500	125.0	
	472 (皮带)	170	Y315L2-4-200		8350	139.2	
	530 (皮带)	216	Y355M2-4-250		9450	157.5	

## 2BE3 系列技术性能表/2BE3 Technical Parameters

型号 Model	转速 Speed (r/min)	轴功率 Shaft power (kW)	配用电机 Motor Power (KW)	极限真空度 Limit vacuum	最大抽气速率 Suction capacity		泵头重 Weight excluding motor (kg)
					m <sup>3</sup> /h	m <sup>3</sup> /min	
2BE3-40	300 (皮带/减速机)	64.8	6-75	160hPa (-0.085Mpa)	4200	70	4050
	330 (皮带/减速机)	75	6-90		4650	77	
	350 (皮带/减速机)	86.5	110		4860	81	
	390 (皮带/减速机)	99	110		5460	91	
	430 (皮带/减速机)	117	132		6000	100	
	(皮带/减速机)	135	160		6900	115	
	530 (皮带/减速机)	148	185		7440	124	
	570 (皮带/减速机)	167	200		8000	133	
2BE3-42	300 (皮带/减速机)	100	6-110	160hPa (-0.085Mpa)	5850	97.5	4200
	350 (皮带/减速机)	109	132		6300	105	
	390 (皮带/减速机)	133	160		7650	127	
	449 (皮带/减速机)	157	185		8550	142	
	490 (皮带/减速机)	180	200		9200	154	
	530 (皮带/减速机)	200	220		10100	168	
	570 (皮带/减速机)	225	250		10600	177	
	2BE3-50	236 (皮带/减速机)	128		160	160hPa (-0.085Mpa)	
266 (皮带/减速机)		140	160	8500	142		
300 (皮带/减速机)		173	200	10000	167		
336 (皮带/减速机)		235	250	11400	190		
366 (皮带/减速机)		261	280	12500	208		
420 (减速机)		278	315	13700	228		
2BE3-52	236 (皮带/减速机)	168	185	160hPa (-0.085Mpa)	9000	150	6500
	266 (皮带/减速机)	175	200		10560	176	
	336 (皮带/减速机)	260	280		13800	230	
	366 (减速机)	285	315		15000	250	
	421 (减速机)	331	400		16800	280	
	468 (减速机)	416	500		18450	307	
2BE3-60	236 (减速机)	204	250	160hPa (-0.085Mpa)	11820	197	8900
	265 (减速机)	243	280		14200	236	
	295 (减速机)	285	315		15900	265	
	340 (减速机)	365	400		17400	290	
	370 (减速机)	386	450		19400	323	
2BE3-62	200 (减速机)	195	250	160hPa (-0.085Mpa)	13200	220	9250
	230 (减速机)	260	315		15180	253	
	266 (减速机)	300	355		17300	288.3	
	297 (减速机)	348	400		19300	322	
	330 (减速机)	395	450		21300	355	
	372 (减速机)	490	560		24000	400	
2BE3-67	180 (减速机)	250	315	160hpa (-0.085Mpa)	14500	242	12200
	210 (减速机)	285	315		18000	300	
	270 (减速机)	415	450		22800	380	
	300 (减速机)	465	560		25800	430	
	330 (减速机)	545	630		27720	462	
	370 (减速机)	670	800		30960	516	
2BE3-72	190 (减速机)	338	400	160hpa (-0.085Mpa)	20100	335	15000
	210 (减速机)	395	450		23760	396	
	240 (减速机)	475	560		27000	450	
	270 (减速机)	550	630		30000	500	
	300 (减速机)	642	710		33600	560	
2BE3-80N	190 (减速机)	507	560	160hpa (-0.085Mpa)	30000	500	19000
	210 (减速机)	585	630		32280	538	
	240 (减速机)	710	800		36600	610	
	270 (减速机)	849	900		40800	680	
	300 (减速机)	796	1000		44800	748	
2BE3-90N	170 (减速机)	570	630	160hpa (-0.085Mpa)	39000	650	24500
	195 (减速机)	730	800		46800	780	
	210 (减速机)	815	900		49800	830	
	230 (减速机)	925	1000		52800	880	
	245 (减速机)	1035	1120		55800	930	
2BE3-100N	155 (减速机)	730	800	160hpa (-0.085Mpa)	48000	800	31000
	165 (减速机)	840	900		51300	855	
	175 (减速机)	900	1000		54000	900	
	190 (减速机)	995	1120		59400	990	
	200 (减速机)	1146	1250		62400	1040	

## 2BE1-102

注：右图是吸气温度为 20°C，工作液温度为 15°C，出口压力为一个标准大气压(1013mbar)，吸入介质为饱和空气时泵的性能曲线，性能允差 ±10%

Note: the performance curve is obtained under the following condition: suction temperature 20°C, operating liquid 15°C; outlet pressure is 1 atmospheric pressure (1013mbar); inlet medium is saturated air; tolerance ±10%.

转速 r/min	不同吸气压力下的工作液（水）流量 Working Liquid(water)Flow Volume of Different Suction Pressure		
	<200 mbar m <sup>3</sup> /h	200... 600mbar m <sup>3</sup> /h	>600 mbar m <sup>3</sup> /h
1750	1.5	1.1	0.5
1450	1.3	0.9	0.4

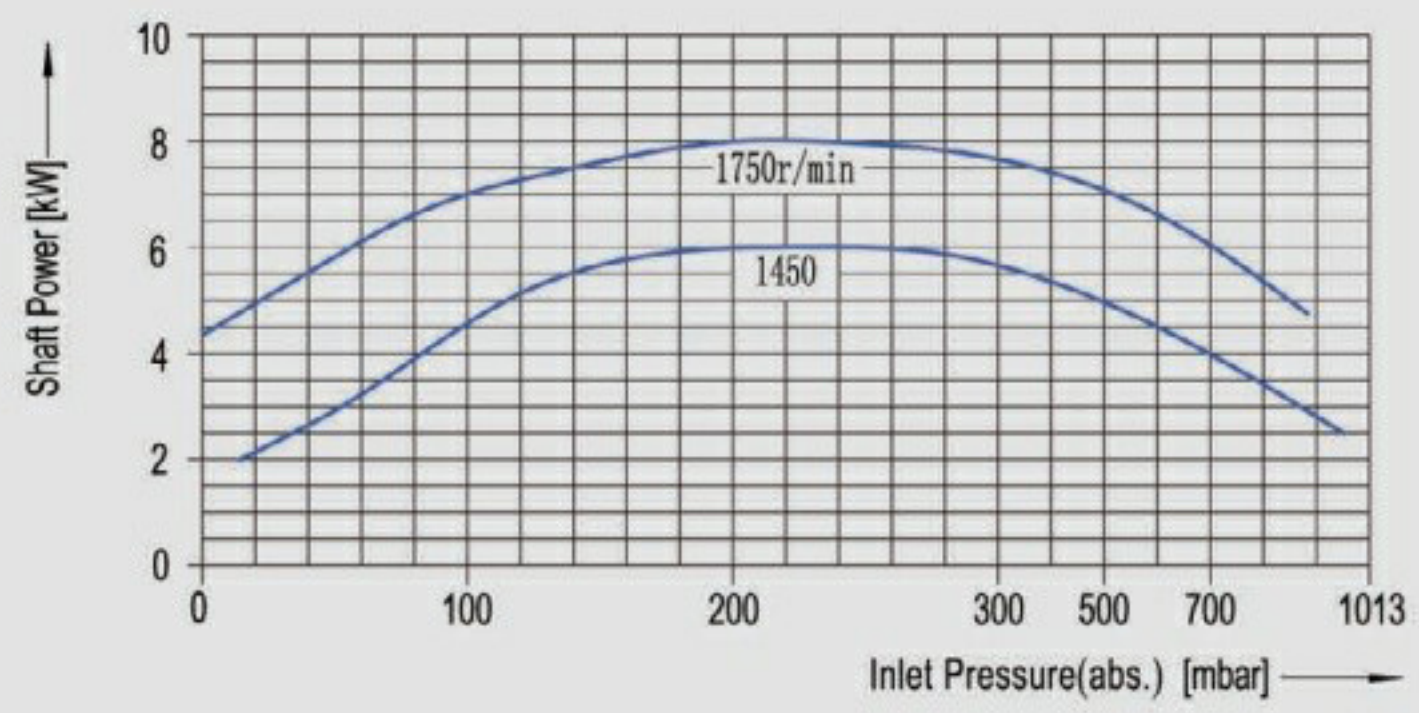
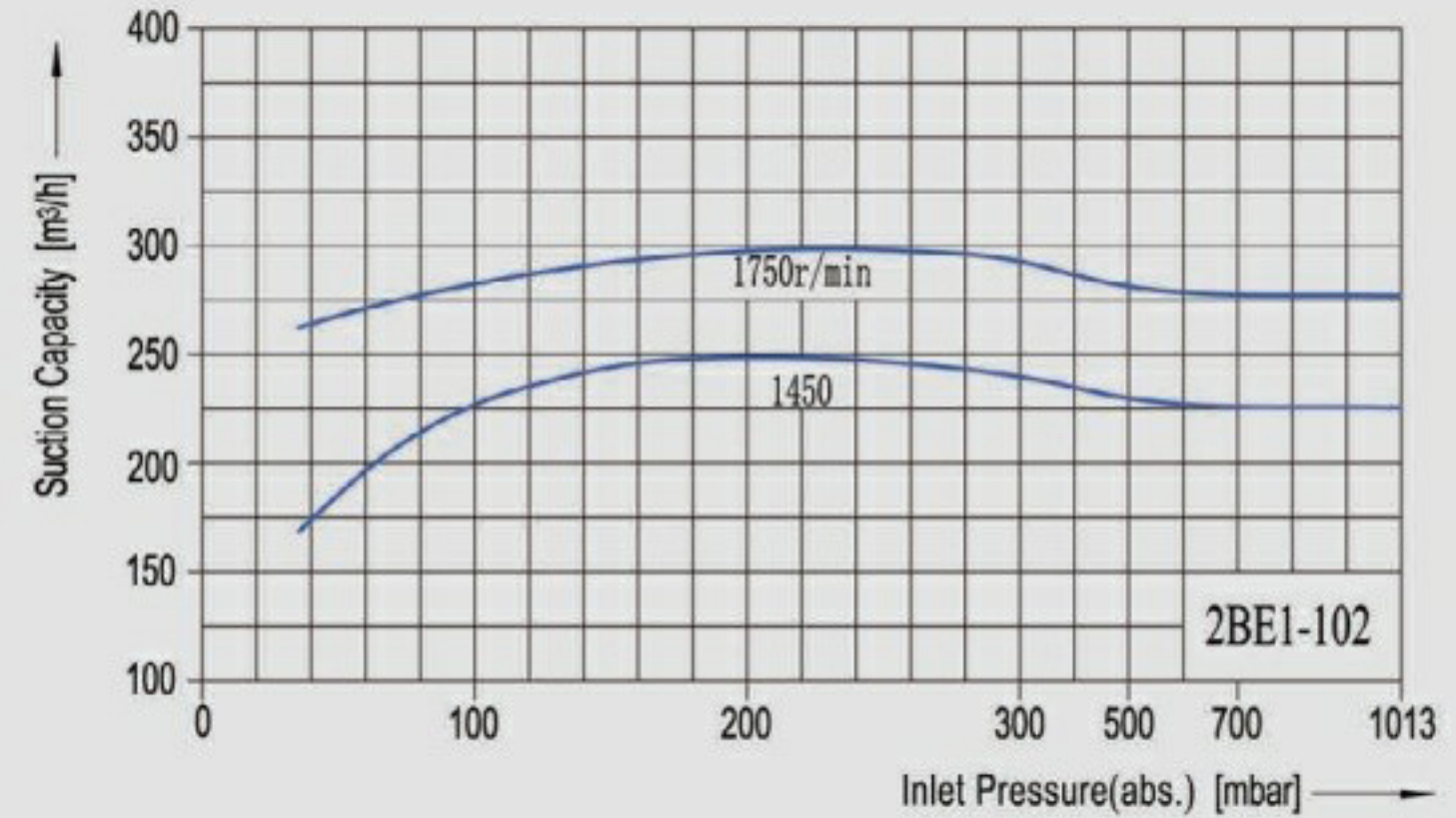

## 2BE1-103

注：右图是吸气温度为 20°C，工作液温度为 15°C，出口压力为一个标准大气压(1013mbar)，吸入介质为饱和空气时泵的性能曲线，性能允差 ±10%

Note: the performance curve is obtained under the following condition: suction temperature 20°C, operating liquid 15°C; outlet pressure is 1 atmospheric pressure (1013mbar); inlet medium is saturated air; tolerance ±10%.

转速 r/min	不同吸气压力下的工作液（水）流量 Working Liquid(water)Flow Volume of Different Suction Pressure		
	<200 mbar m <sup>3</sup> /h	200... 600mbar m <sup>3</sup> /h	>600 mbar m <sup>3</sup> /h
1750	1.7	1.13	0.57
1450	1.4	0.93	0.47

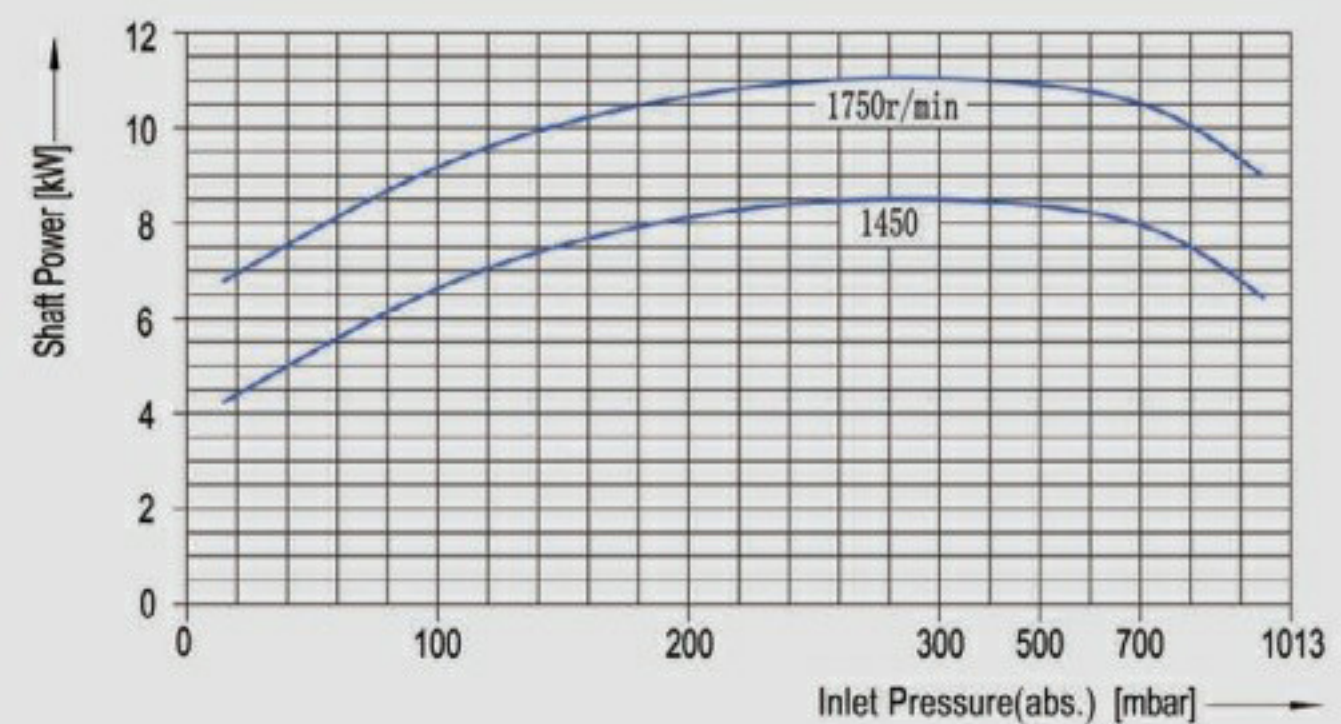
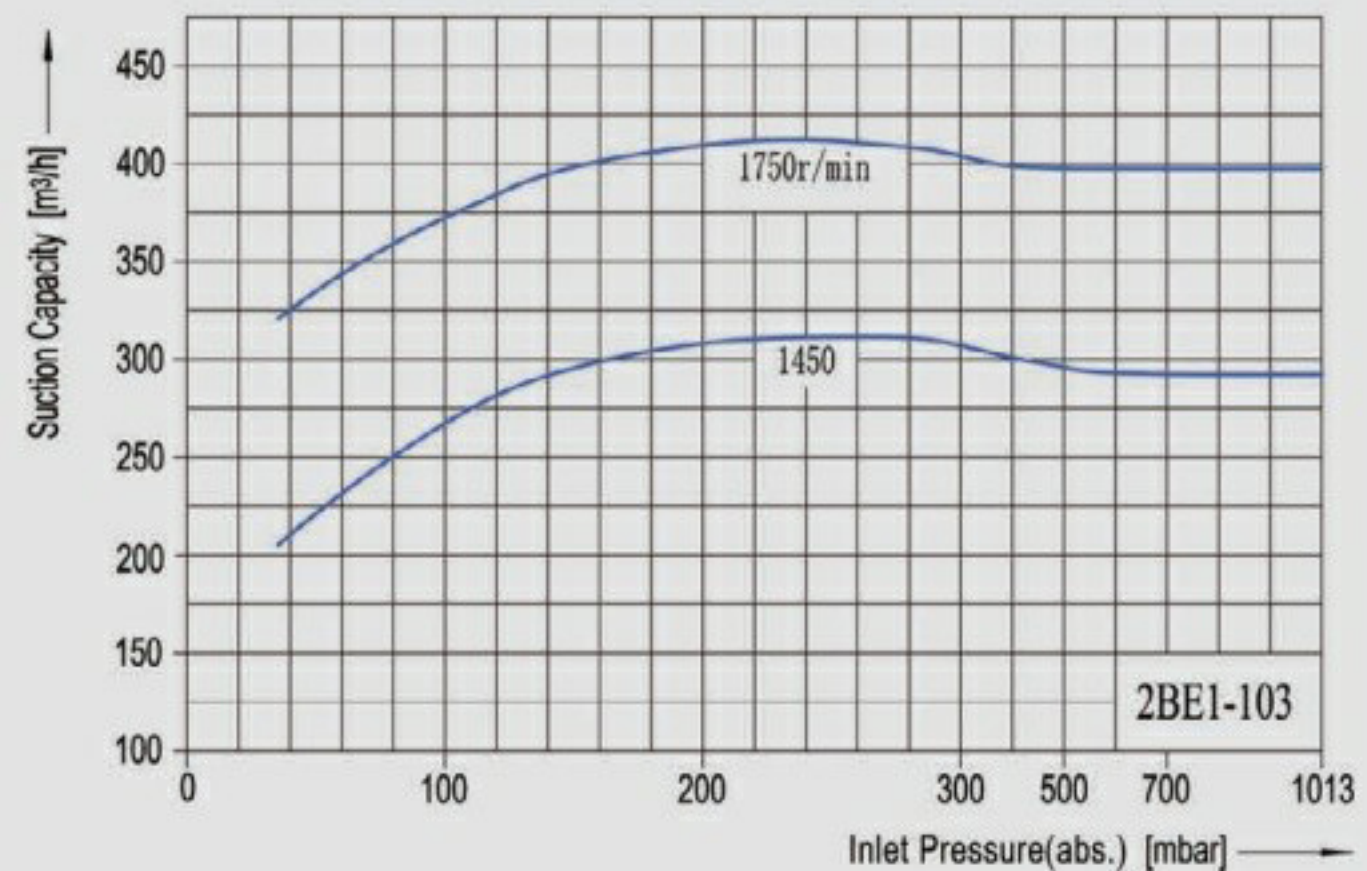

## 2BE1-152

注：右图是吸气温度为 20°C，工作液温度为 15°C，出口压力为一个标准大气压(1013mbar)，吸入介质为饱和空气时泵的性能曲线，性能允差 ±10%

Note: the performance curve is obtained under the following condition: suction temperature 20°C, operating liquid 15°C; outlet pressure is 1 atmospheric pressure (1013mbar); inlet medium is saturated air; tolerance ±10%.

转速 (speed) r/min	不同吸气压力下的工作液(水)流量 Working Liquid(water)Flow Volume of Different Suction Pressure		
	<200 mbar m <sup>3</sup> /h	200... 600mbar m <sup>3</sup> /h	>600 mbar m <sup>3</sup> /h
1810	2.2	1.5	0.73
1750	2.1	1.4	0.7
1625	1.9	1.27	0.63
1450	1.7	1.13	0.57
1300	1.5	1	0.5
1100	1.2	0.8	0.4

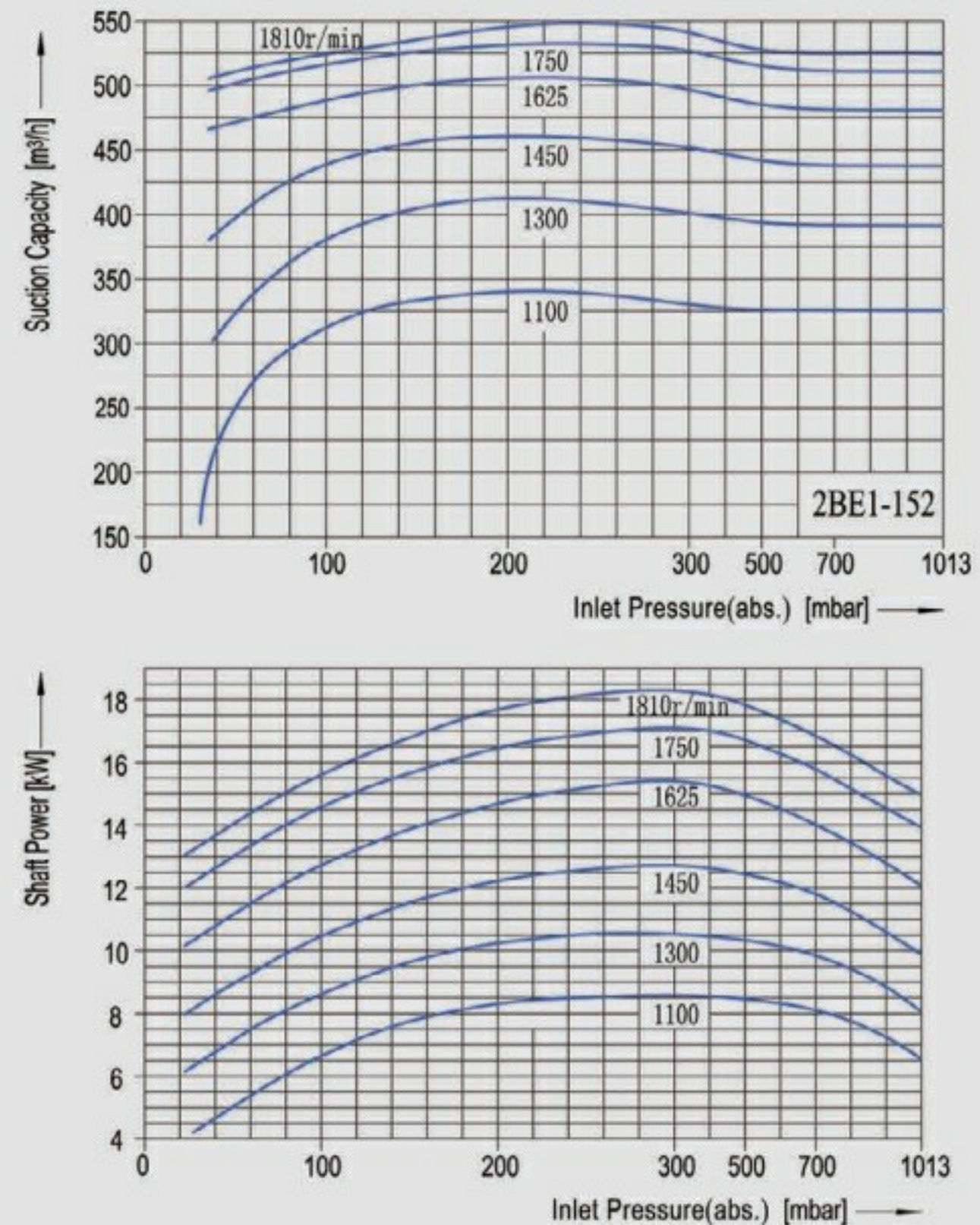

## 2BE1-153

注：右图是吸气温度为 20°C，工作液温度为 15°C，出口压力为一个标准大气压(1013mbar)，吸入介质为饱和空气时泵的性能曲线，性能允差 ±10%

Note: the performance curve is obtained under the following condition: suction temperature 20°C, operating liquid 15°C; outlet pressure is 1 atmospheric pressure (1013mbar); inlet medium is saturated air; tolerance ±10%.

转速 (speed) r/min	不同吸气压力下的工作液(水)流量 Working Liquid(water)Flow Volume of Different Suction Pressure		
	<200 mbar m <sup>3</sup> /h	200... 600mbar m <sup>3</sup> /h	>600 mbar m <sup>3</sup> /h
1810	2.4	1.6	0.8
1750	2.3	1.53	0.7
1625	2.1	1.4	0.63
1450	1.9	1.13	0.57
1300	1.7	1	0.5
1100	1.4	0.93	0.4

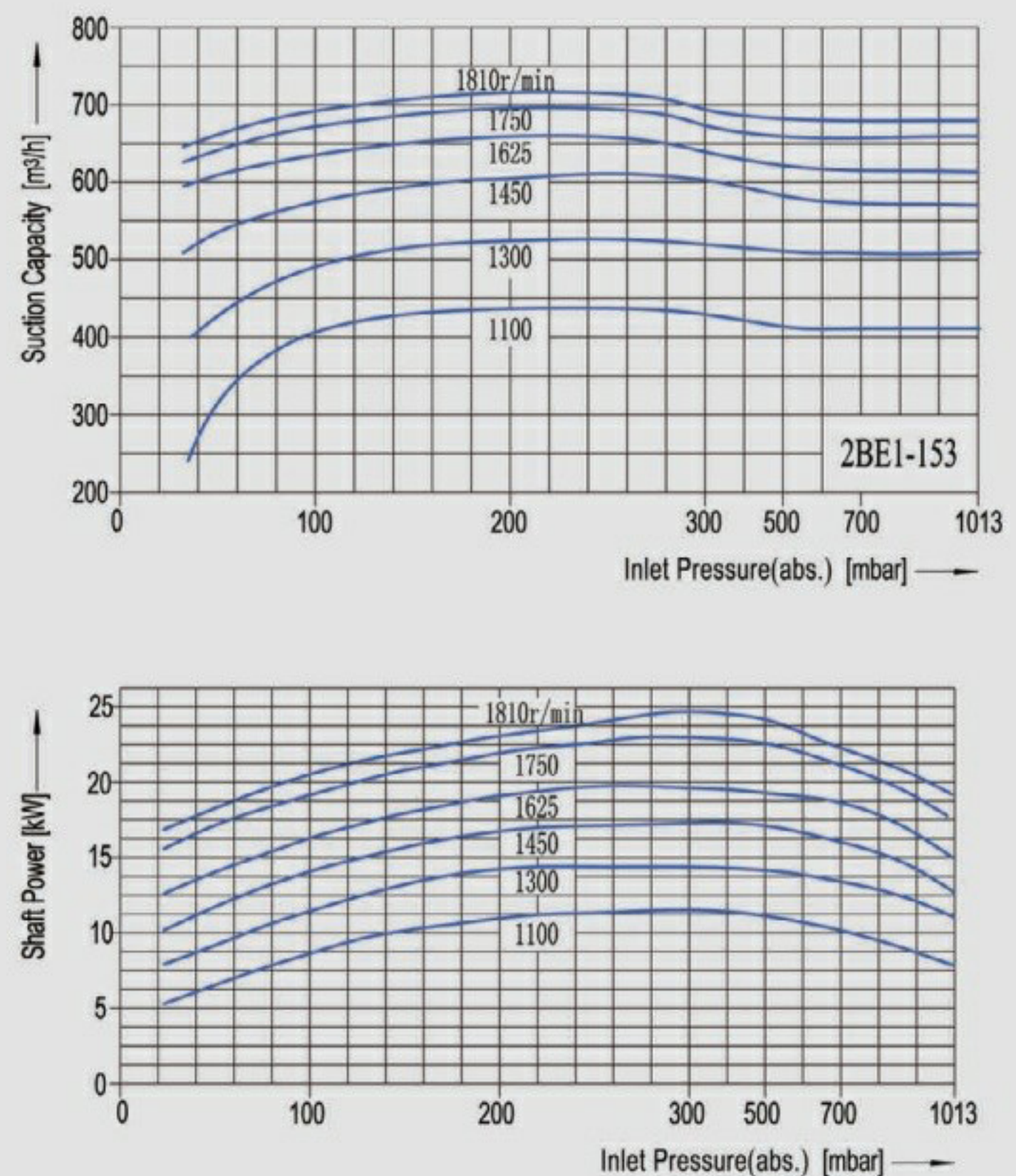

## 2BE1-202

注：右图是吸气温度为 20°C，工作液温度为 15°C，出口压力为一个标准大气压(1013mbar)，吸入介质为饱和空气时泵的性能曲线，性能允差 ±10%

Note: the performance curve is obtained under the following condition: suction temperature 20°C, operating liquid 15°C; outlet pressure is 1 atmospheric pressure (1013mbar); inlet medium is saturated air; tolerance ±10%.

转速 (speed) r/min	不同吸气压力下的工作液(水)流量 Working Liquid(water)Flow Volume of Different Suction Pressure		
	<200 mbar m <sup>3</sup> /h	200... 600mbar m <sup>3</sup> /h	>600 mbar m <sup>3</sup> /h
1300	2.7	1.8	0.9
1170	2.5	1.67	0.83
1100	2.3	1.53	0.77
980	2.1	1.4	0.7
880	1.9	1.27	0.63
790	1.7	1.1	0.57

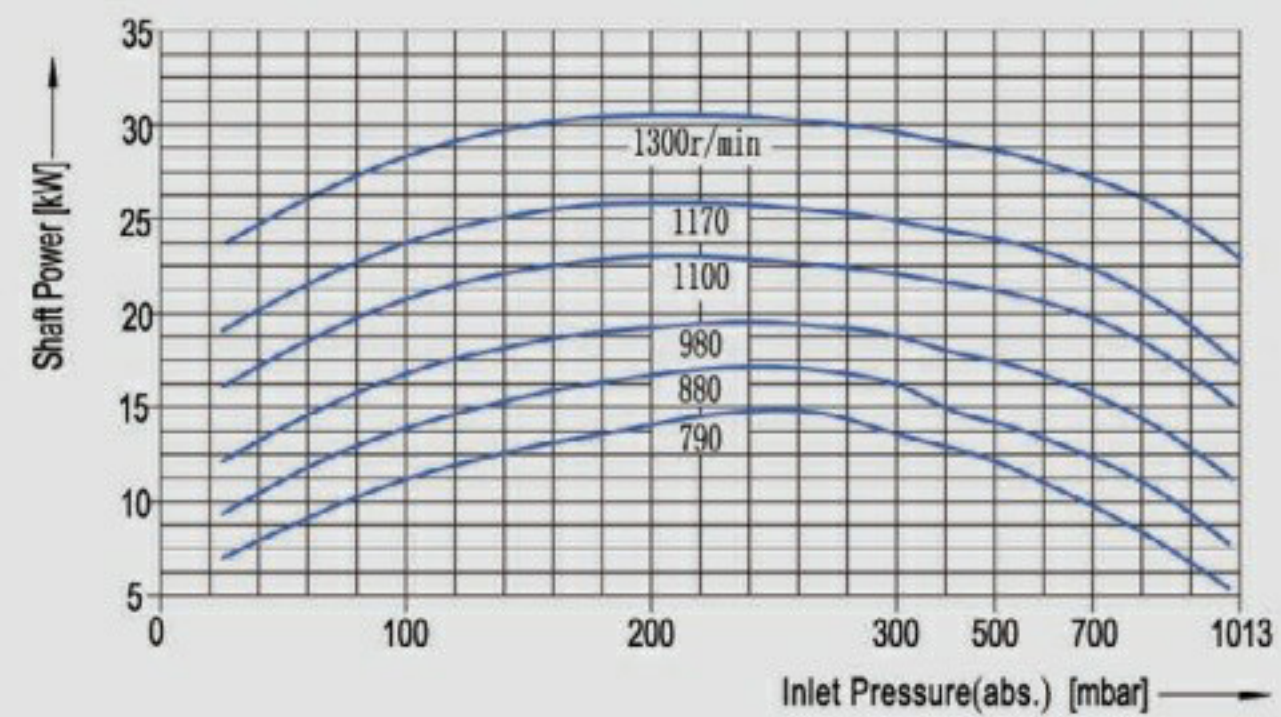
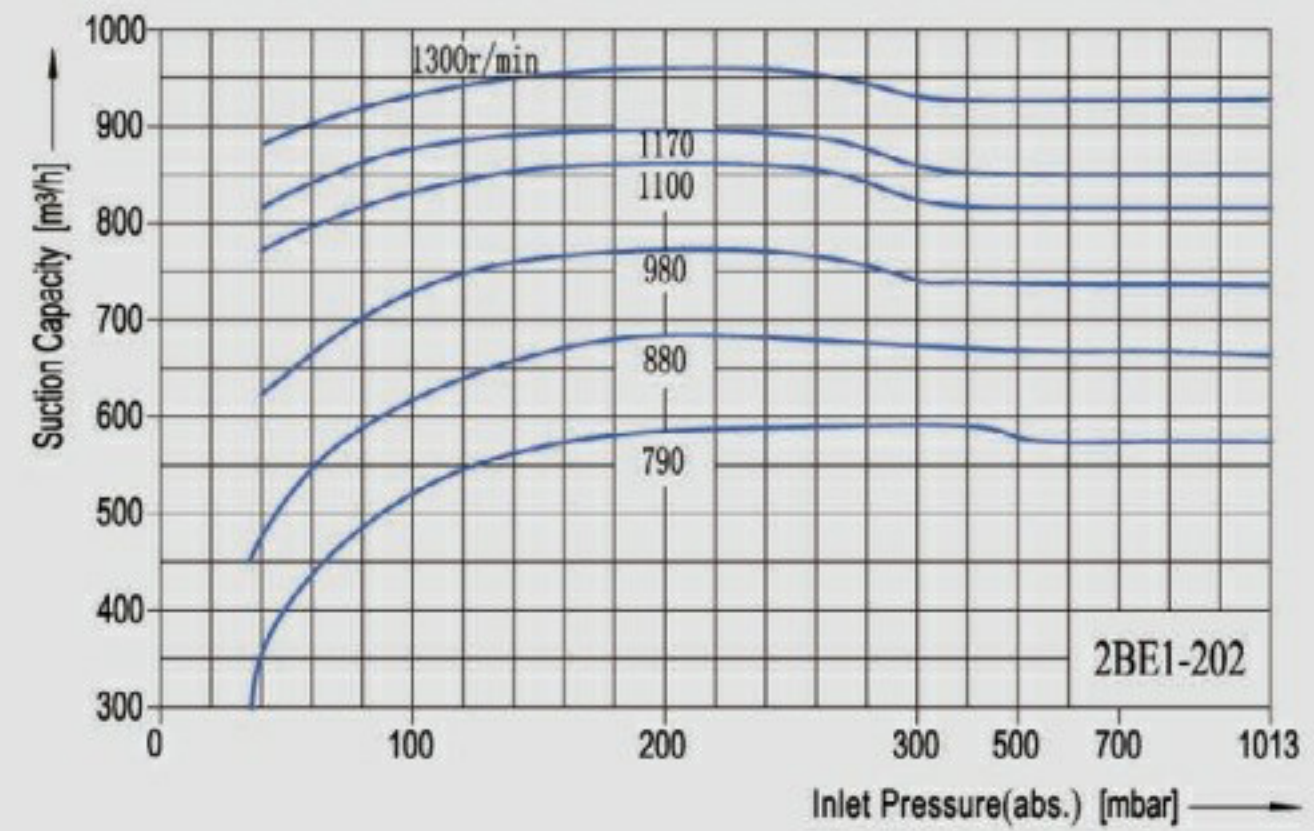

## 2BE1-203

注：右图是吸气温度为 20°C，工作液温度为 15°C，出口压力为一个标准大气压(1013mbar)，吸入介质为饱和空气时泵的性能曲线，性能允差 ±10%

Note: the performance curve is obtained under the following condition: suction temperature 20°C, operating liquid 15°C; outlet pressure is 1 atmospheric pressure (1013mbar); inlet medium is saturated air; tolerance ±10%.

转速 (speed) r/min	不同吸气压力下的工作液(水)流量 Working Liquid(water)Flow Volume of Different Suction Pressure		
	<200 mbar m <sup>3</sup> /h	200... 600mbar m <sup>3</sup> /h	>600 mbar m <sup>3</sup> /h
1300	3.4	2.3	1.1
1170	3.1	2.07	1.03
1100	2.9	1.93	0.97
980	2.6	1.73	0.87
880	2.3	1.53	0.77
790	2.1	1.4	0.7

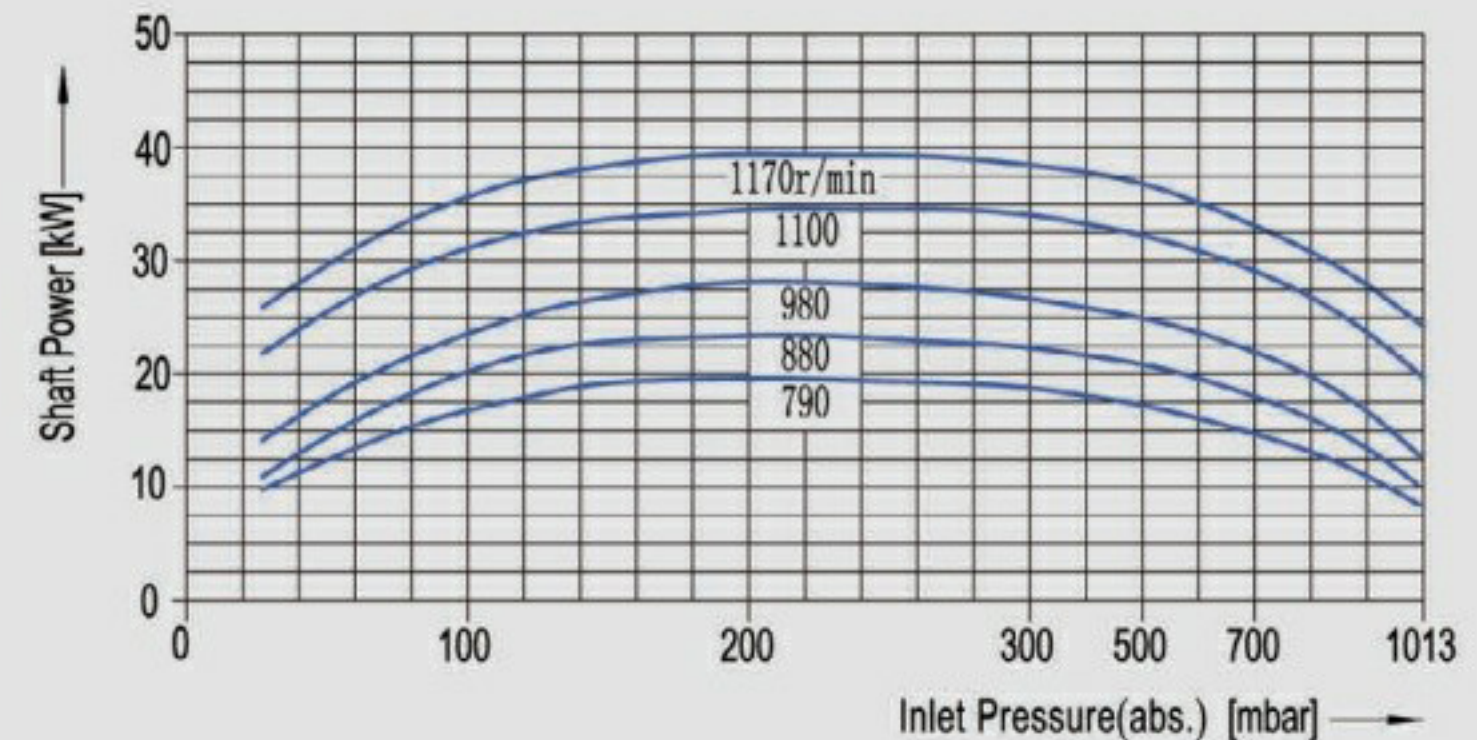
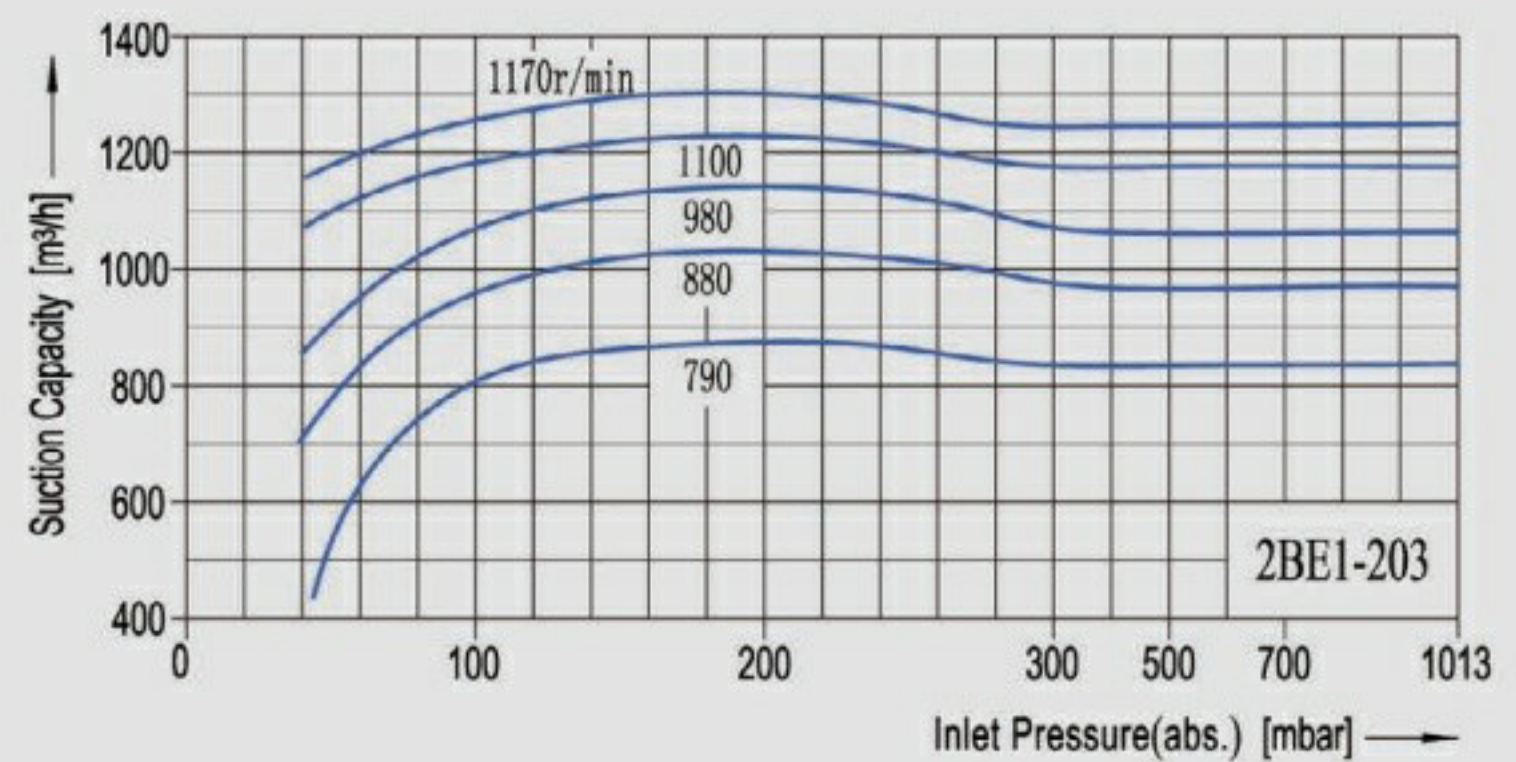

## 2BE1-252

注：右图是吸气温度为 20°C，工作液温度为 15°C，出口压力为一个标准大气压(1013mbar)，吸入介质为饱和空气时泵的性能曲线，性能允差 ±10%

Note: the performance curve is obtained under the following condition: suction temperature 20°C, operating liquid 15°C; outlet pressure is 1 atmospheric pressure (1013mbar); inlet medium is saturated air; tolerance ±10%.

转速 (speed) r/min	不同吸气压力下的工作液（水）流量 Working Liquid(water)Flow Volume of Different Suction Pressure		
	<200 mbar m <sup>3</sup> /h	200... 600mbar m <sup>3</sup> /h	>600 mbar m <sup>3</sup> /h
880	5.2	3.7	1.73
820	4.9	3.27	1.63
740	4.4	2.93	1.47
660	3.9	2.6	1.3
565	3.3	2.2	1.1

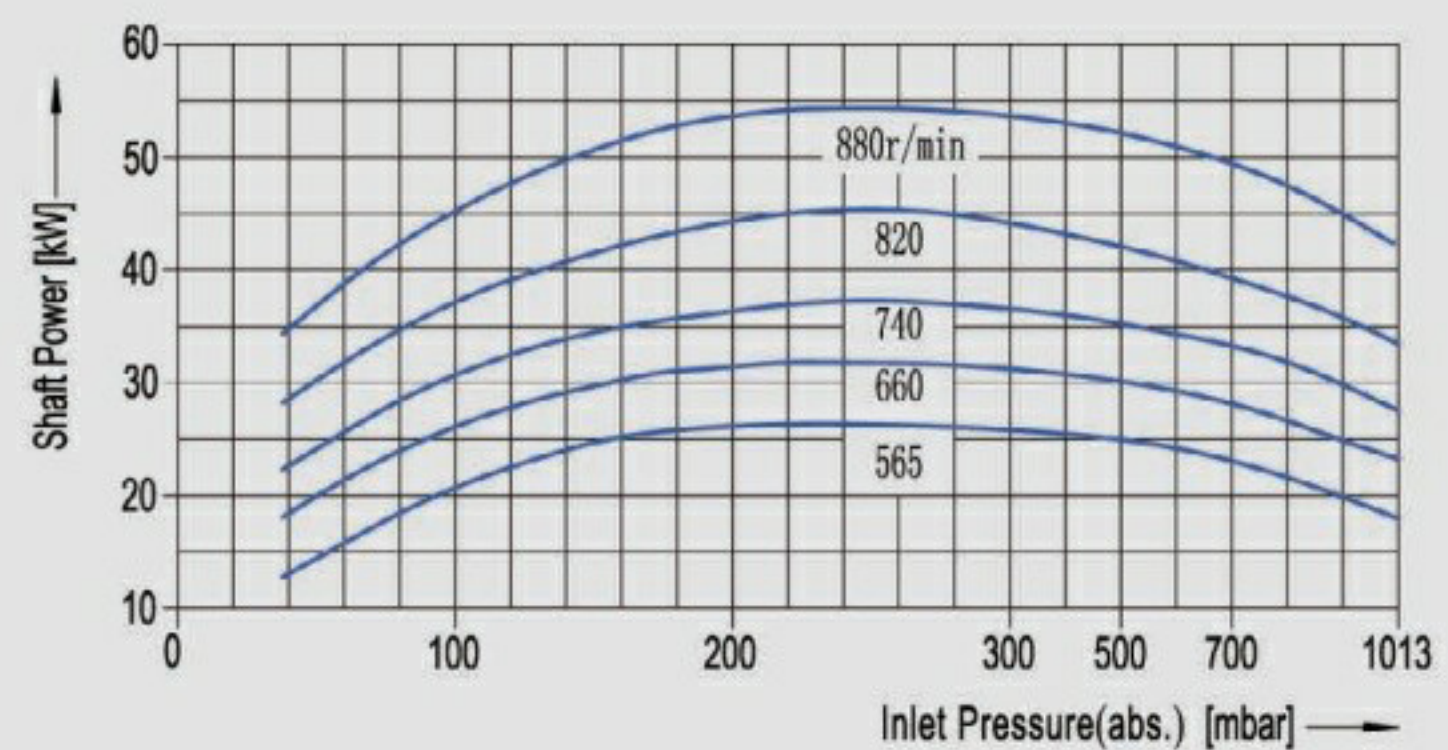
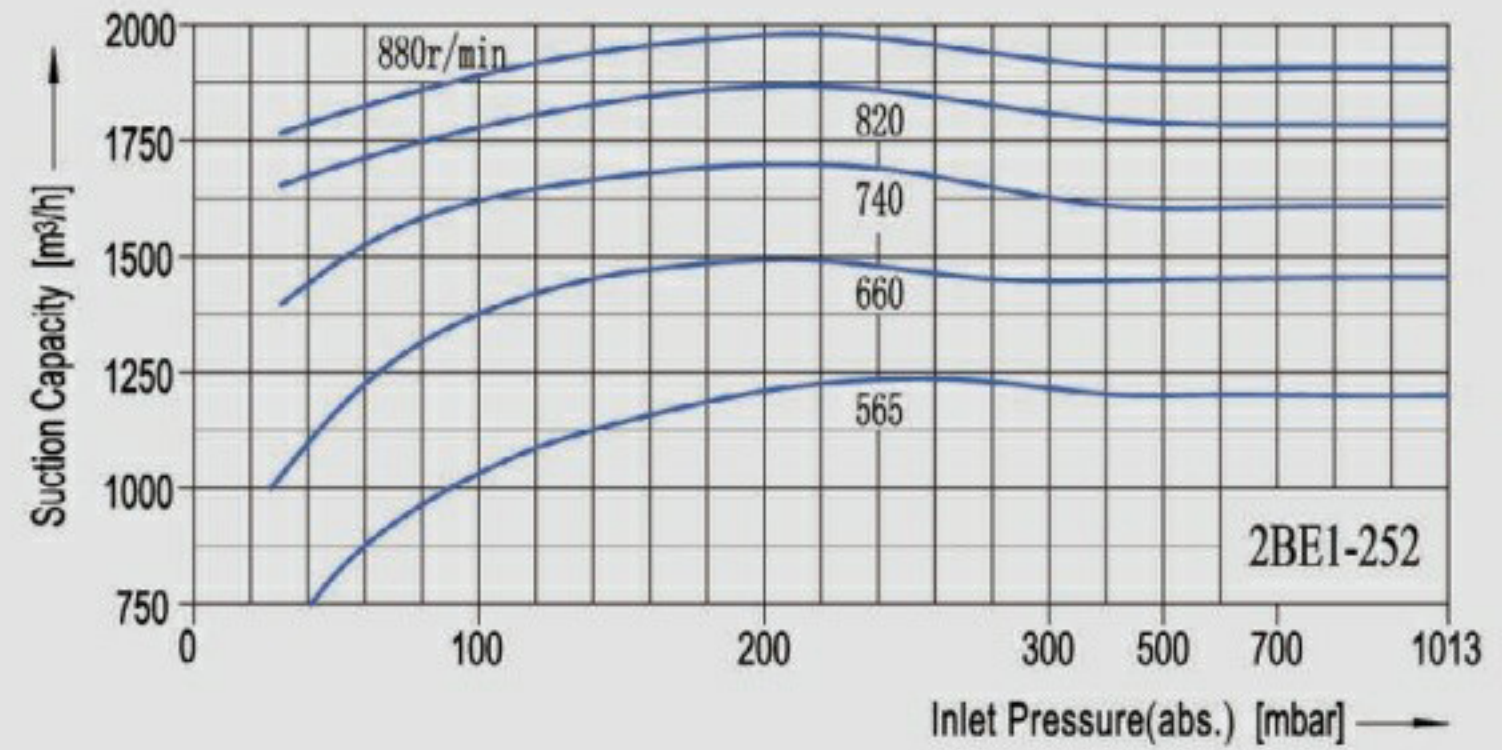

## 2BE1-253

注：右图是吸气温度为 20°C，工作液温度为 15°C，出口压力为一个标准大气压(1013mbar)，吸入介质为饱和空气时泵的性能曲线，性能允差 ±10%

Note: the performance curve is obtained under the following condition: suction temperature 20°C, operating liquid 15°C; outlet pressure is 1 atmospheric pressure (1013mbar); inlet medium is saturated air; tolerance ±10%.

转速 (speed) r/min	不同吸气压力下的工作液（水）流量 Working Liquid(water)Flow Volume of Different Suction Pressure		
	<200 mbar m <sup>3</sup> /h	200... 600mbar m <sup>3</sup> /h	>600 mbar m <sup>3</sup> /h
880	6.2	4.14	2.06
820	5.8	3.87	1.93
740	5.2	3.47	1.73
660	4.6	3.07	1.53
565	3.9	2.6	1.3

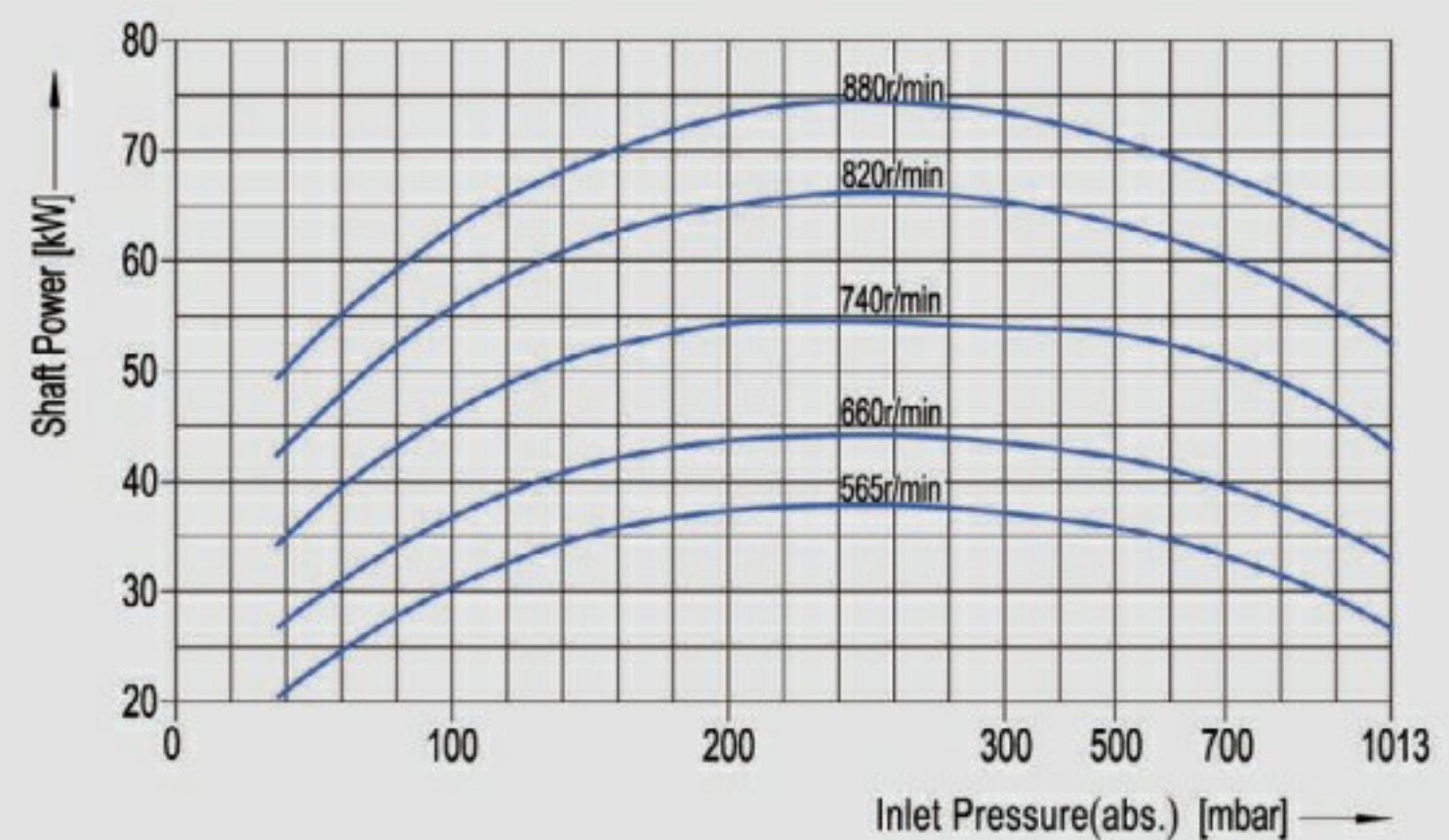
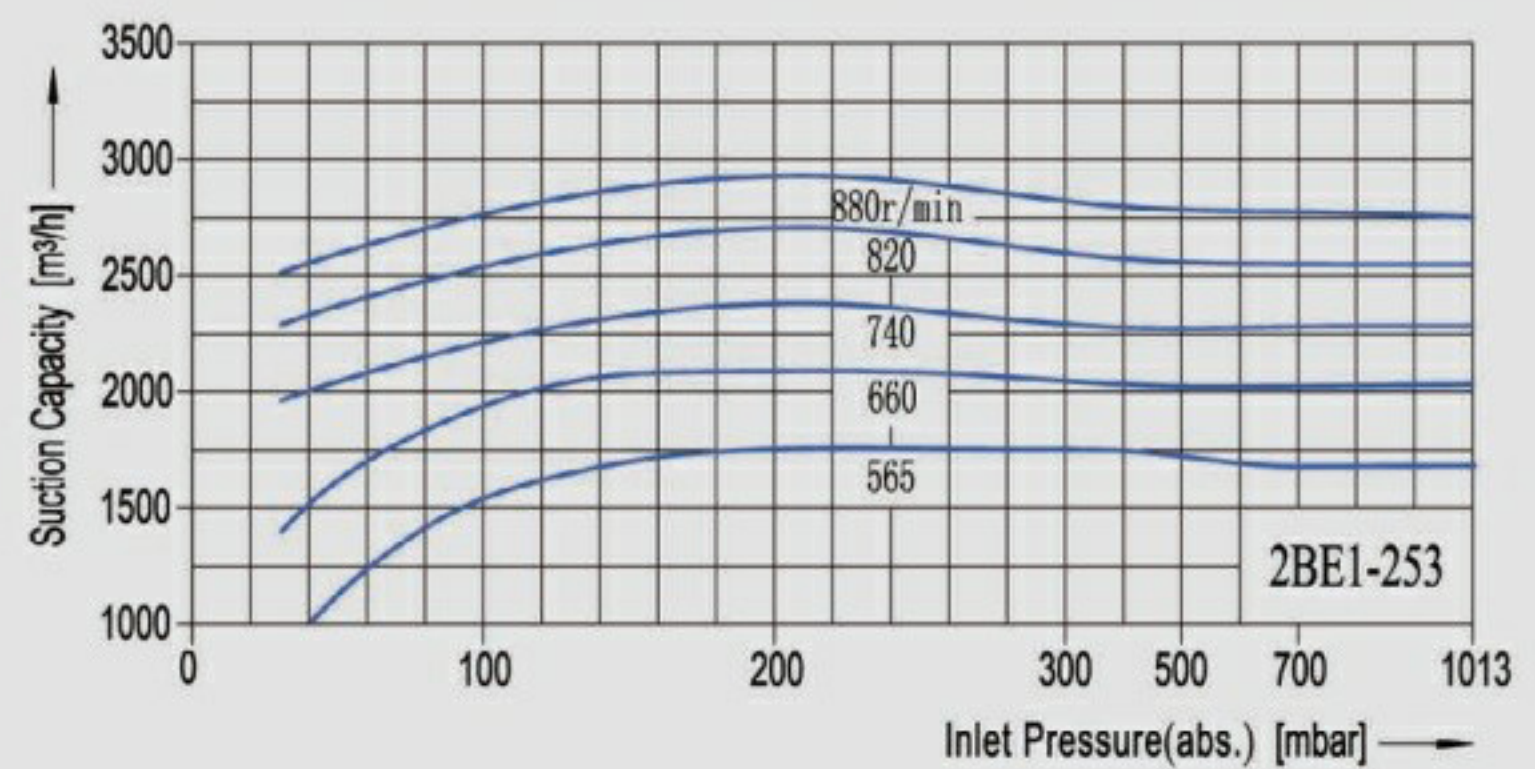

## 2BE1-303

注：右图是吸气温度为 20°C，工作液温度为 15°C，出口压力为一个标准大气压(1013mbar)，吸入介质为饱和空气时泵的性能曲线，性能允差 ±10%

Note: the performance curve is obtained under the following condition: suction temperature 20°C, operating liquid 15°C; outlet pressure is 1 atmospheric pressure (1013mbar); inlet medium is saturated air; tolerance ±10%.

转速 (speed) r/min	不同吸气压力下的工作液（水）流量 Working Liquid(water)Flow Volume of Different Suction Pressure			
	<200 mbar m <sup>3</sup> /h	200... 400mbar m <sup>3</sup> /h	400... 600mbar m <sup>3</sup> /h	>600 mbar m <sup>3</sup> /h
790	10.1	8.1	6.8	3.4
740	9.5	7.6	6.4	3.2
710	9.1	7.3	6.1	3.1
660	8.5	6.8	5.7	2.9
590	7.6	6.1	5.1	2.6
530	6.8	5.4	4.6	2.3
500	6.4	5.1	4.3	2.2
472	6.1	4.9	4.1	2.1

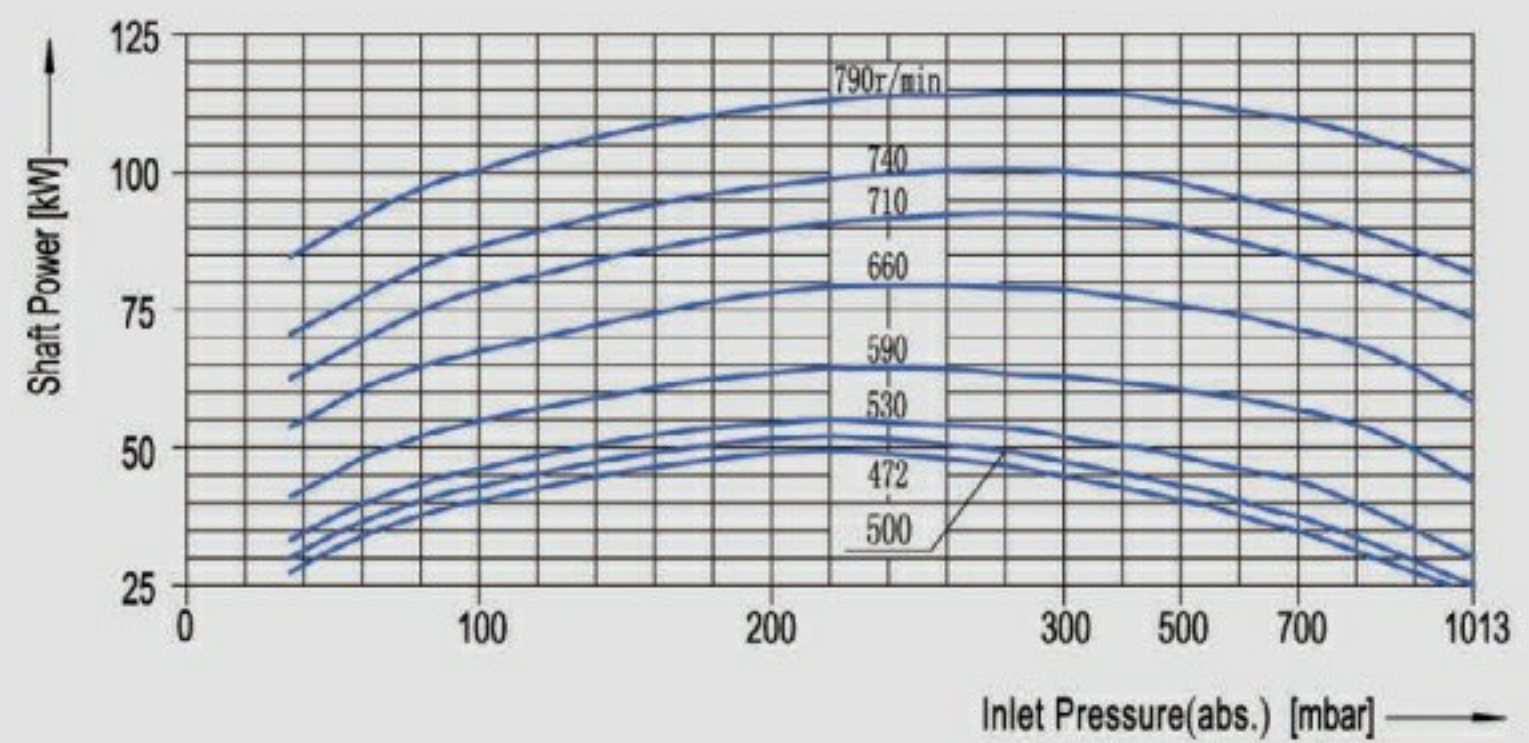
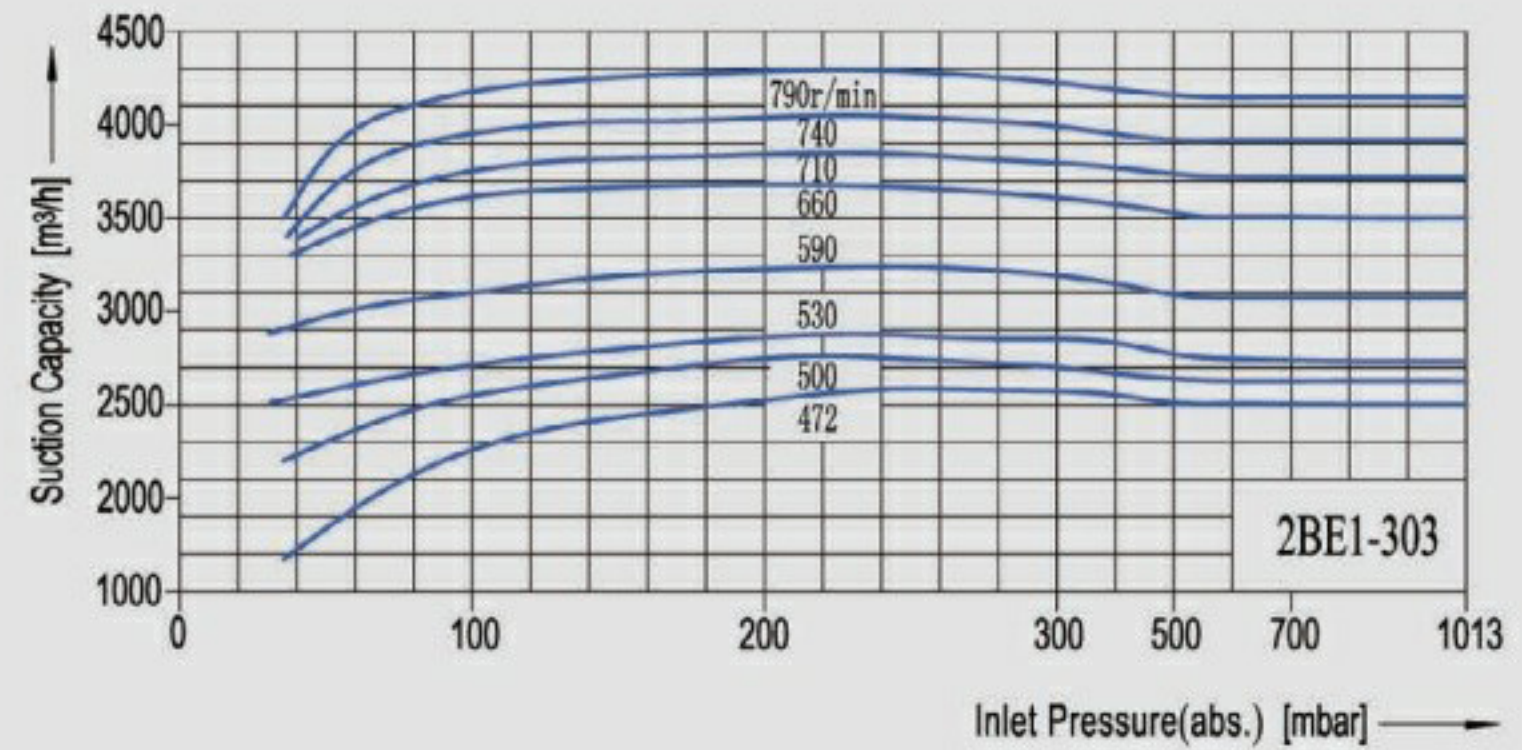

## 2BE1-305

注：右图是吸气温度为 20°C，工作液温度为 15°C，出口压力为一个标准大气压(1013mbar)，吸入介质为饱和空气时泵的性能曲线，性能允差 ±10%

Note: the performance curve is obtained under the following condition: suction temperature 20°C, operating liquid 15°C; outlet pressure is 1 atmospheric pressure (1013mbar); inlet medium is saturated air; tolerance ±10%.

转速 (speed) r/min	不同吸气压力下的工作液（水）流量 Working Liquid(water)Flow Volume of Different Suction Pressure			
	<200 mbar m <sup>3</sup> /h	200... 400mbar m <sup>3</sup> /h	400... 600mbar m <sup>3</sup> /h	>600 mbar m <sup>3</sup> /h
740	9.1	7.77	5.66	4.66
710	8.6	7.5	5.13	4.2
660	8.2	6.23	4.54	3.74
590	7.3	6.23	4.54	3.74
530	6.57	5.61	4.09	3.36
500	6.12	5.31	3.82	3.1
472	5.85	4.99	3.64	2.99

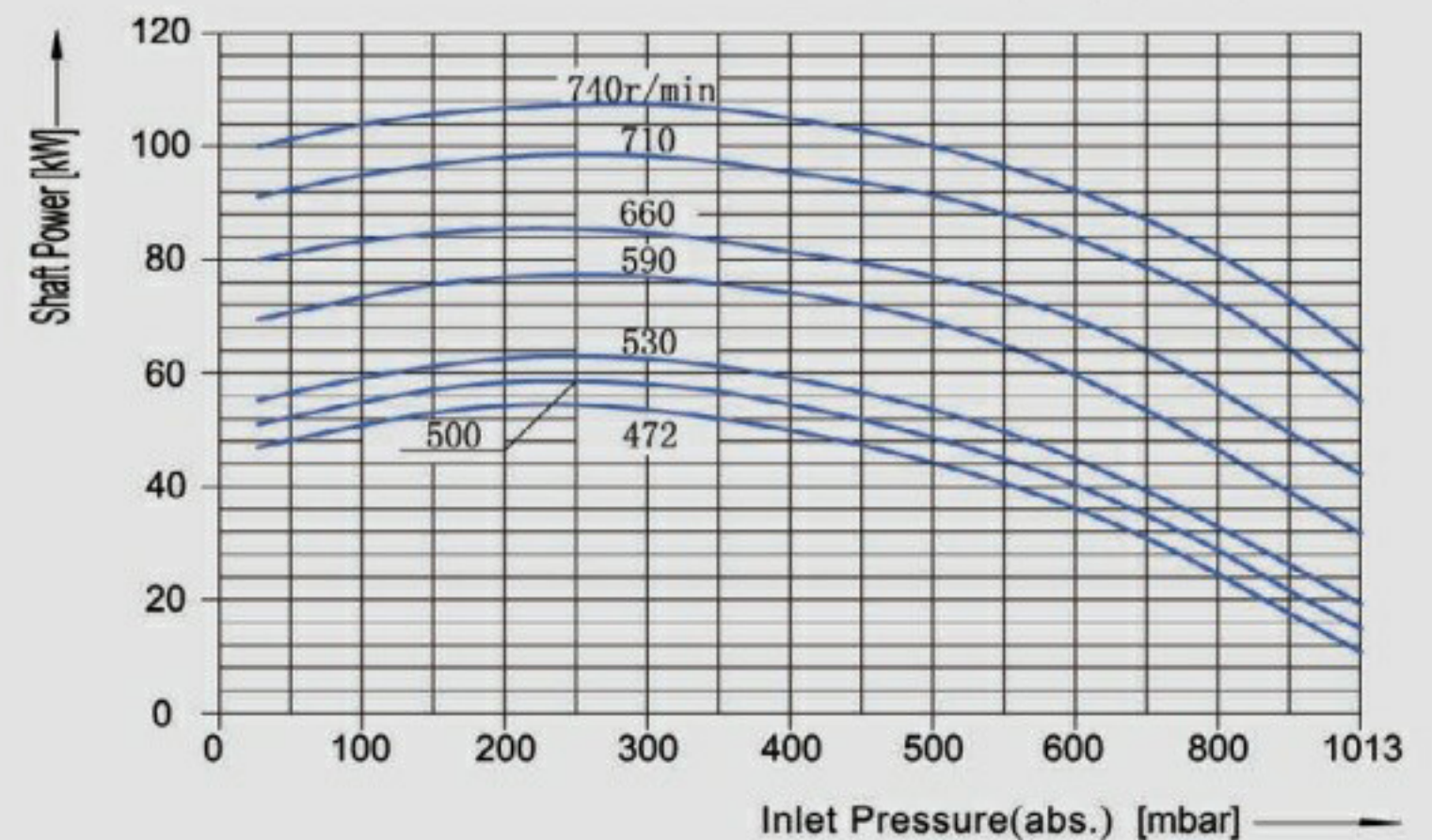
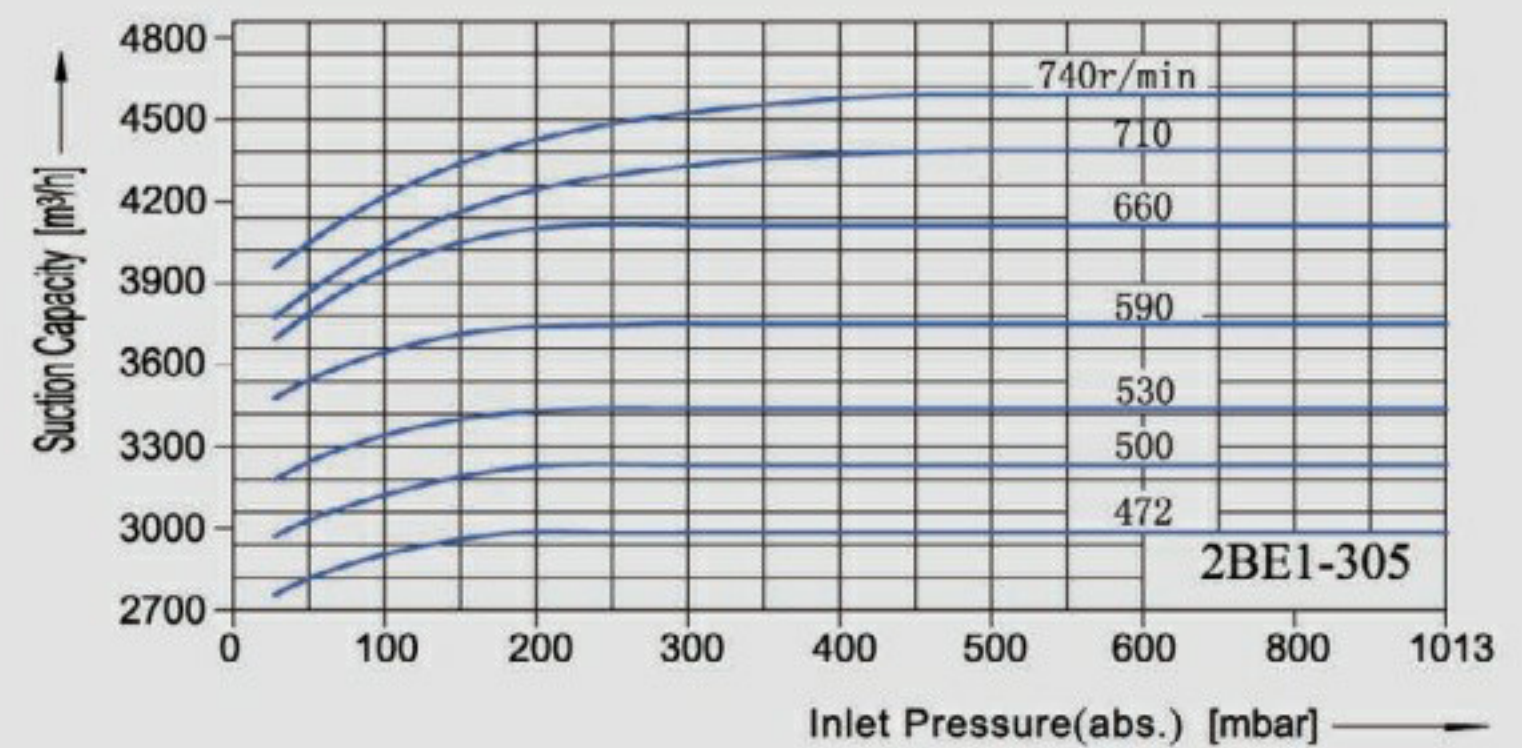

## 2BE1-353

注：右图是吸气温度为 20°C，工作液温度为 15°C，出口压力为一个标准大气压(1013mbar)，吸入介质为饱和空气时泵的性能曲线，性能允差 ±10%

Note: the performance curve is obtained under the following condition: suction temperature 20°C, operating liquid 15°C; outlet pressure is 1 atmospheric pressure (1013mbar); inlet medium is saturated air; tolerance ±10%.

转速 (speed) r/min	不同吸气压力下的工作液（水）流量 Working Liquid(water)Flow Volume of Different Suction Pressure			
	<200 mbar m <sup>3</sup> /h	200... 400mbar m <sup>3</sup> /h	400... 600mbar m <sup>3</sup> /h	>600 mbar m <sup>3</sup> /h
660	14	11.2	9.4	4.8
590	12.5	10	8.4	4.3
530	11.2	9	7.5	3.8
500	10.6	8.5	7.1	3.6
472	10	8	6.7	3.4
420	8.9	7.1	6	3
372	7.9	6.3	5.3	2.7

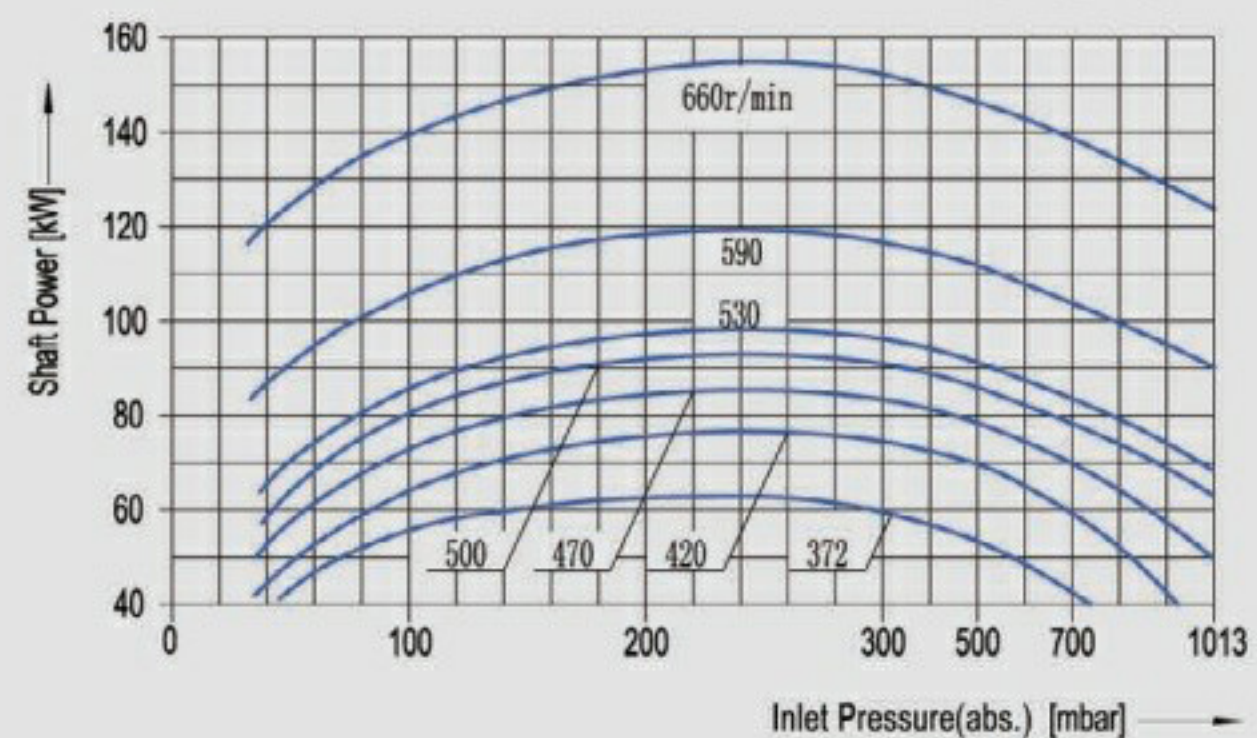
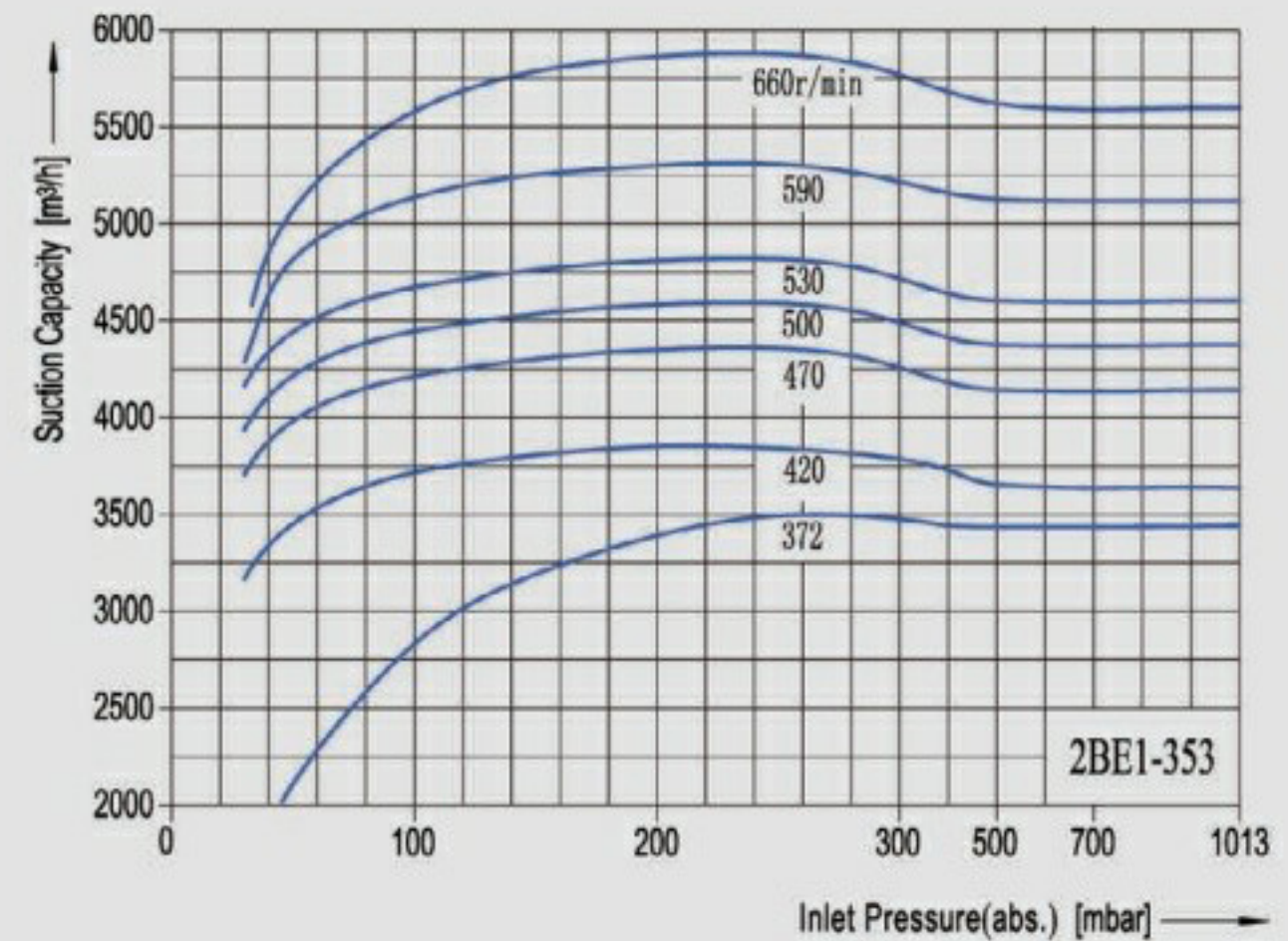

## 2BE1-355

注：右图是吸气温度为 20°C，工作液温度为 15°C，出口压力为一个标准大气压(1013mbar)，吸入介质为饱和空气时泵的性能曲线，性能允差 ±10%

Note: the performance curve is obtained under the following condition: suction temperature 20°C, operating liquid 15°C; outlet pressure is 1 atmospheric pressure (1013mbar); inlet medium is saturated air; tolerance ±10%.

转速 (speed) r/min	不同吸气压力下的工作液（水）流量 Working Liquid(water)Flow Volume of Different Suction Pressure			
	<200 mbar m <sup>3</sup> /h	200... 400mbar m <sup>3</sup> /h	400... 600mbar m <sup>3</sup> /h	>600 mbar m <sup>3</sup> /h
660	13.31	11.36	8.18	6.72
590	11.99	10.23	7.37	6.05
530	10.9	9.3	6.70	5.50
500	10.4	8.9	6.23	5.16
472	9.1	8.2	5.6	5.13
420	8.61	7.34	5.29	4.34
372	7.66	6.54	4.71	3.87

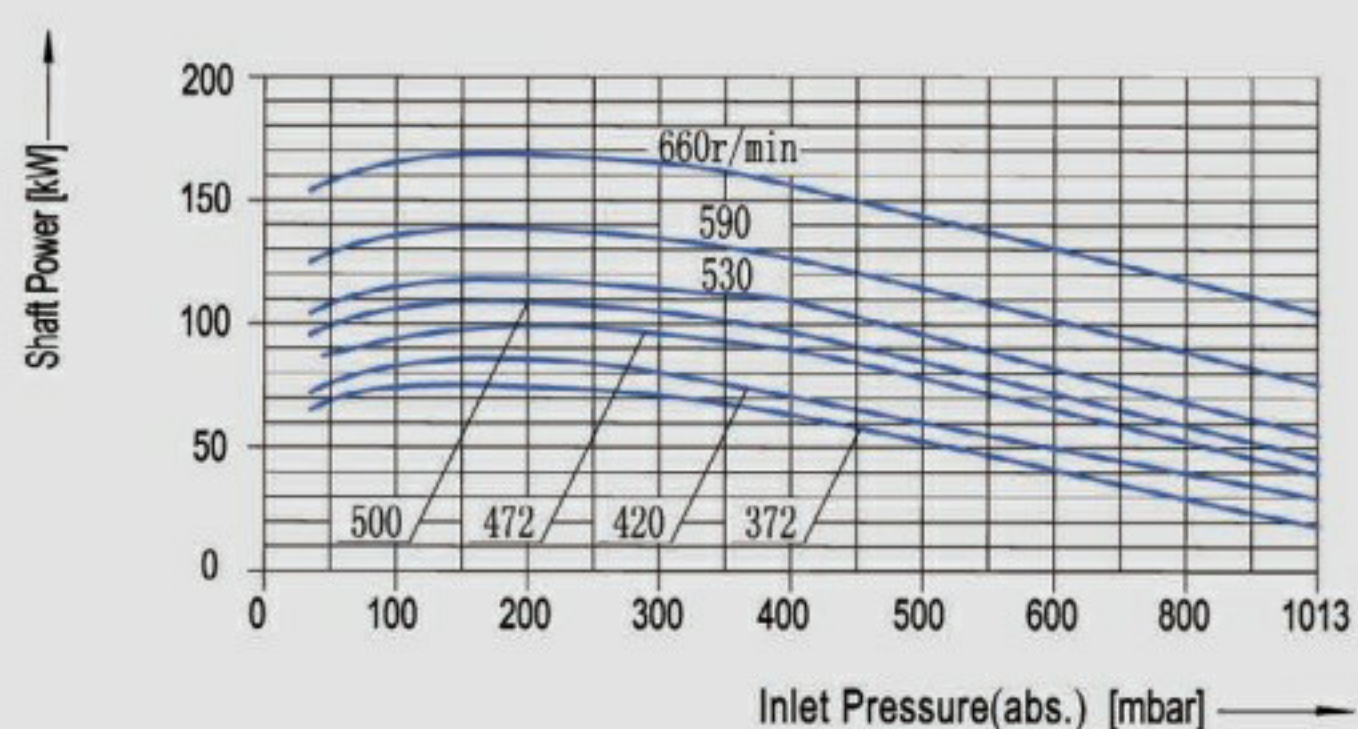
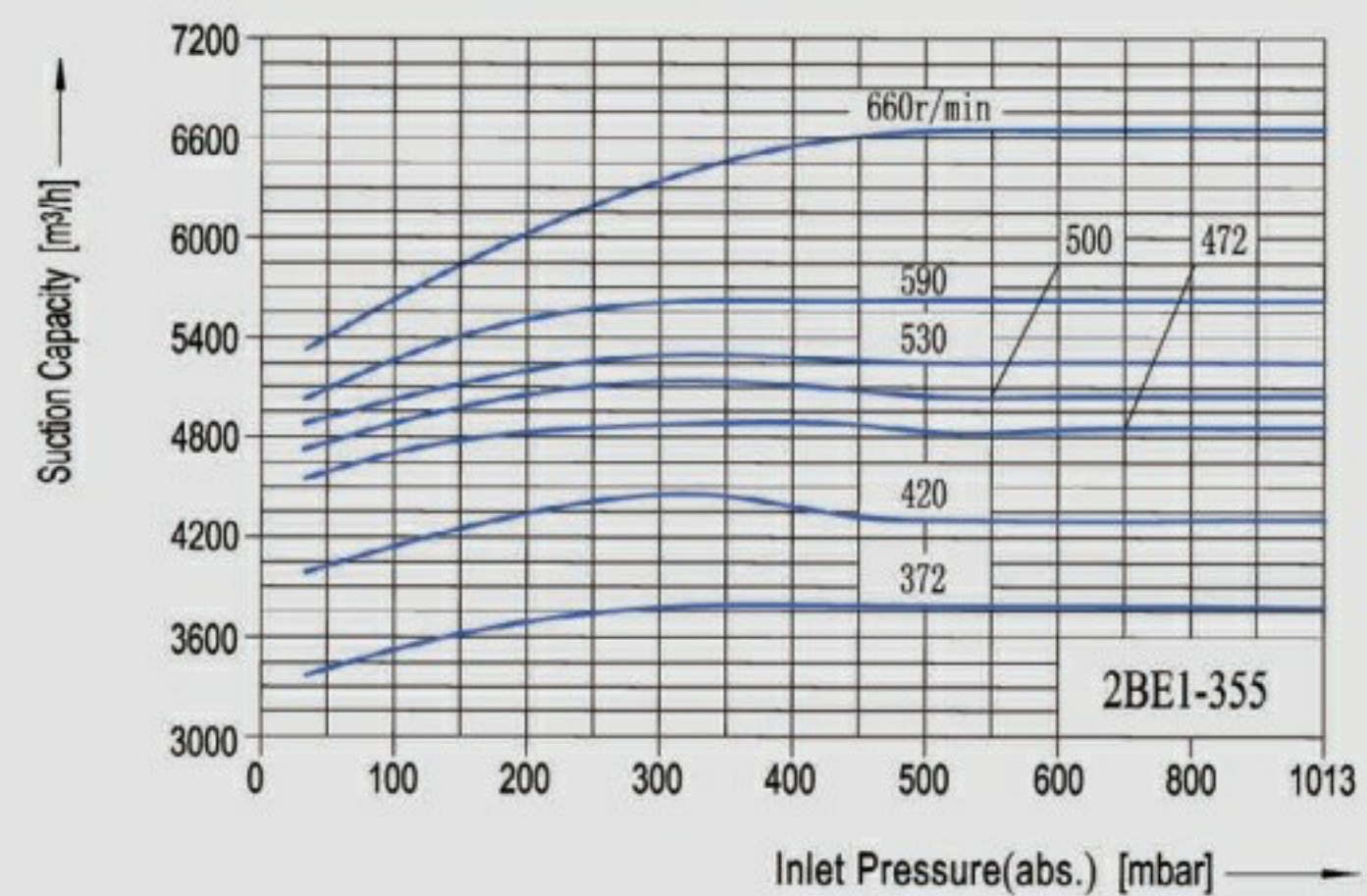

## 2BE1-403

注：右图是吸气温度为 20°C，工作液温度为 15°C，出口压力为一个标准大气压(1013mbar)，吸入介质为饱和空气时泵的性能曲线，性能允差 ±10%

Note: the performance curve is obtained under the following condition: suction temperature 20°C, operating liquid 15°C; outlet pressure is 1 atmospheric pressure (1013mbar); inlet medium is saturated air; tolerance ±10%.

不同吸气压力下的工作液（水）流量 Working Liquid(water).Flow Volume of Different Suction Pressure					
mbar	200	250	300	350	400
m <sup>3</sup> /h	16	14.7	12.8	11.2	10.7
mbar	450	500	550	600	650
m <sup>3</sup> /h	10.5	10.2	9.3	8.7	8.0
mbar	700	750	800		
m <sup>3</sup> /h	7.2	6.7	5.4		

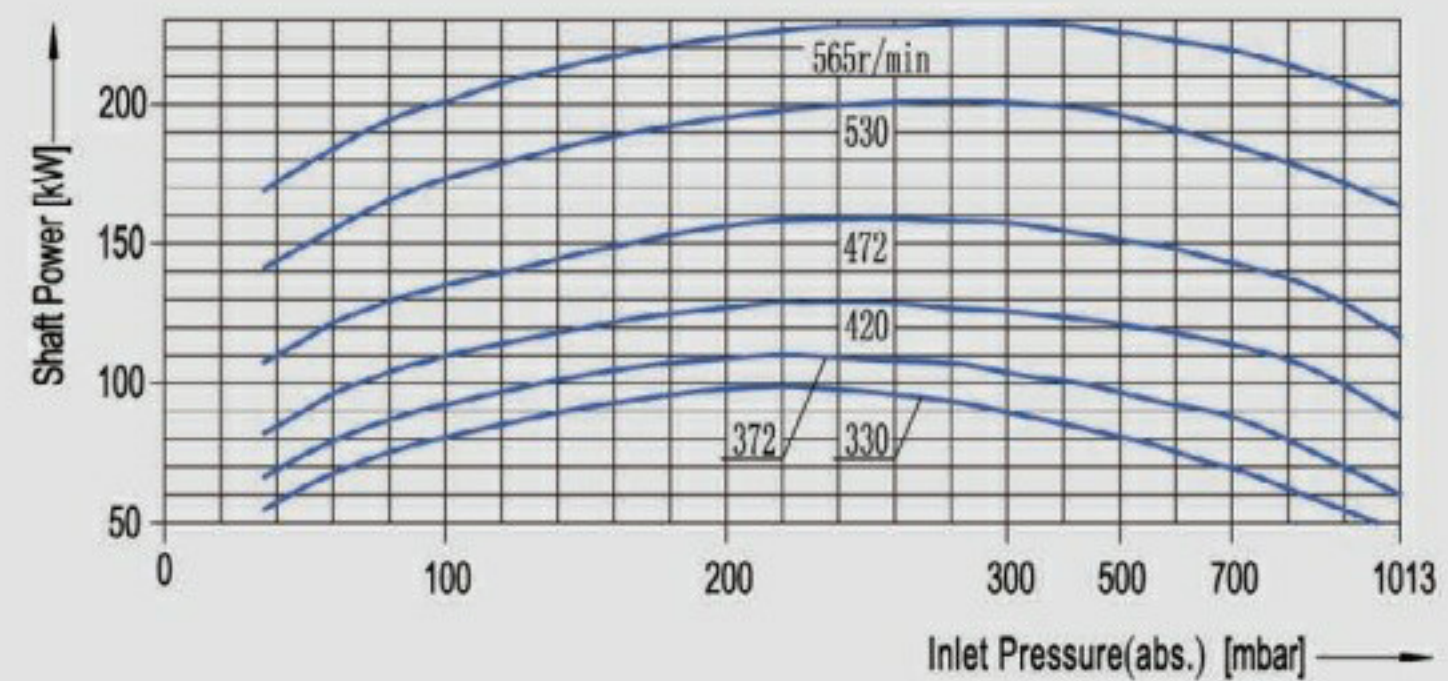
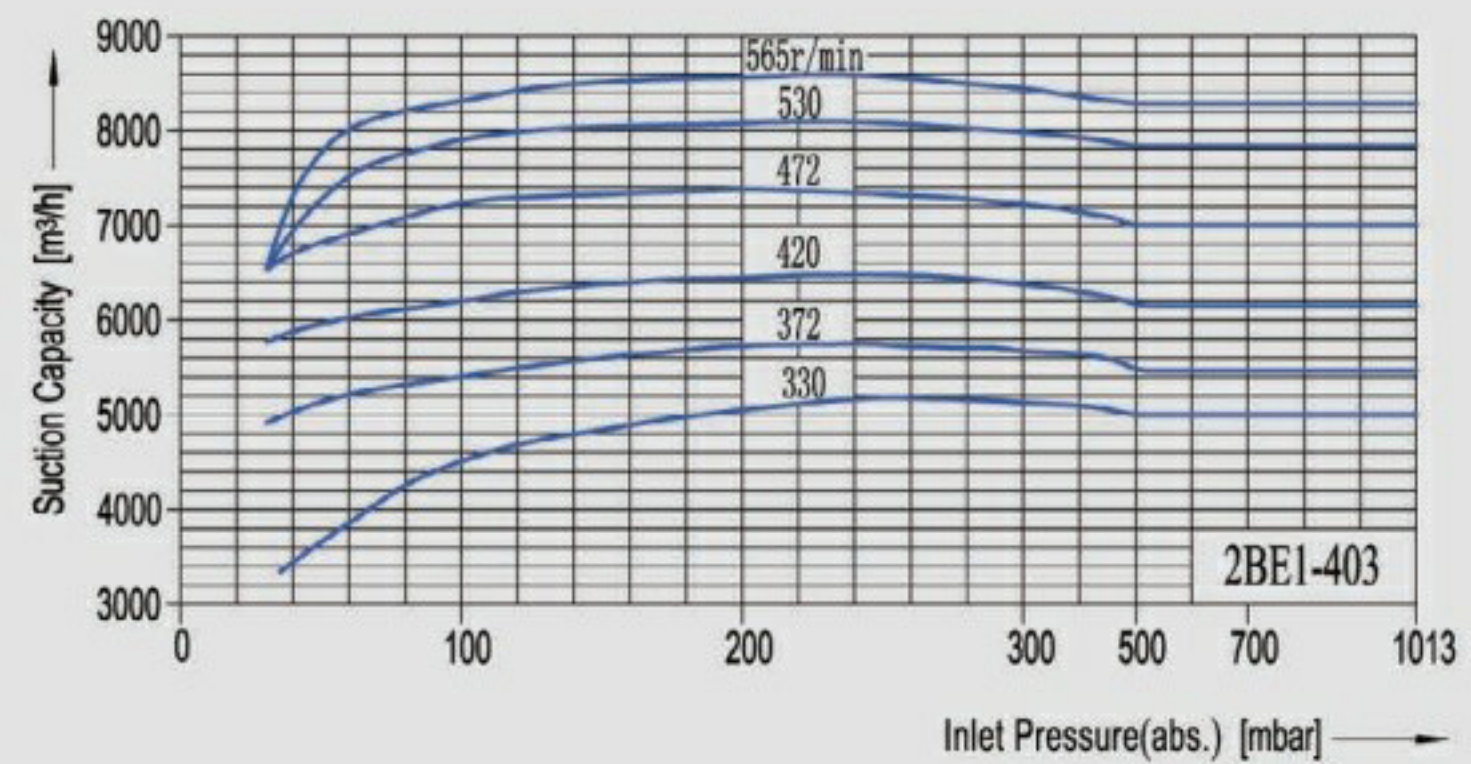

## 2BE1-405

注：右图是吸气温度为 20°C，工作液温度为 15°C，出口压力为一个标准大气压(1013mbar)，吸入介质为饱和空气时泵的性能曲线，性能允差 ±10%

Note: the performance curve is obtained under the following condition: suction temperature 20°C, operating liquid 15°C; outlet pressure is 1 atmospheric pressure (1013mbar); inlet medium is saturated air; tolerance ±10%.

不同吸气压力下的工作液（水）流量 Working Liquid(water)Flow Volume of Different Suction Pressure					
mbar	200	250	300	350	400
m <sup>3</sup> /h	14.7	14.5	14.2	13.1	12.6
mbar	450	500	550	600	650
m <sup>3</sup> /h	11.2	10.9	9.9	9.2	8.4
mbar	700	750	800		
m <sup>3</sup> /h	7.7	6.7	5.9		

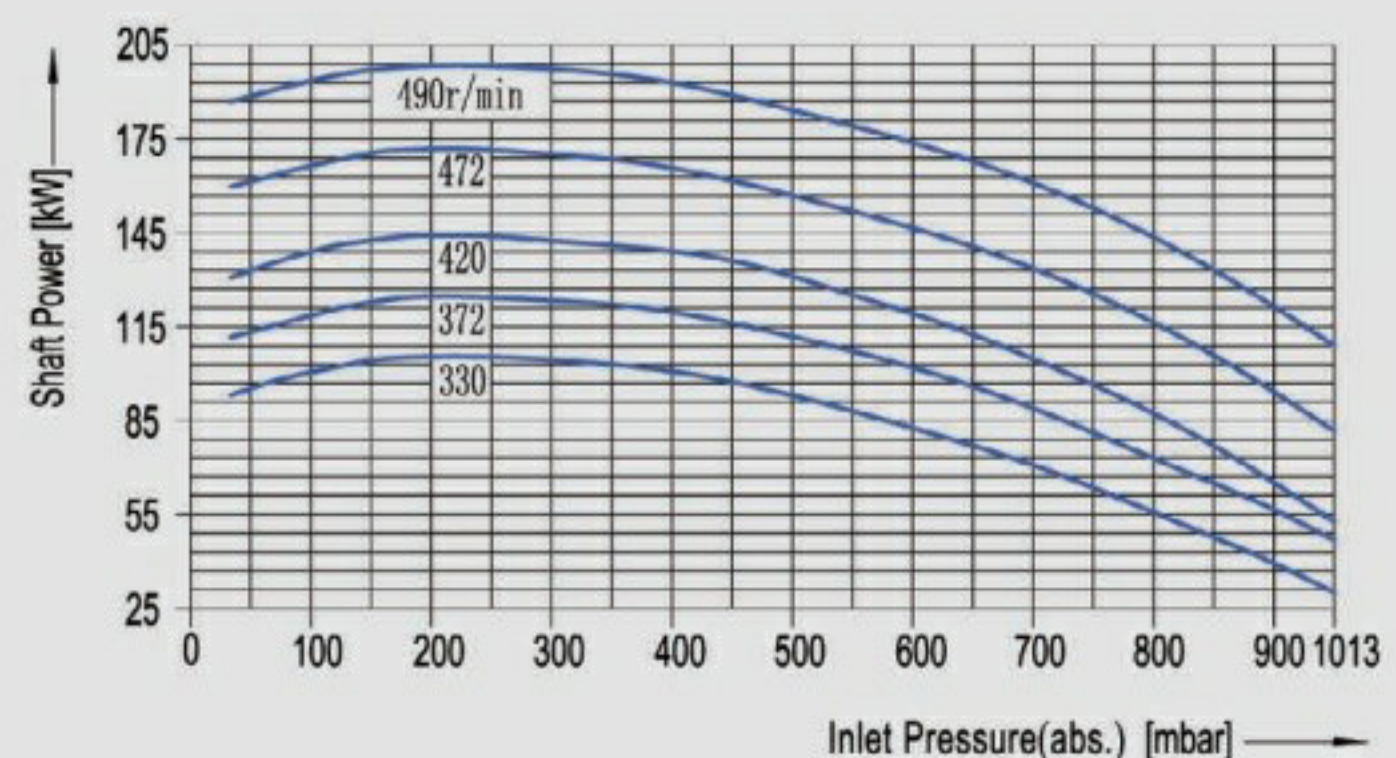
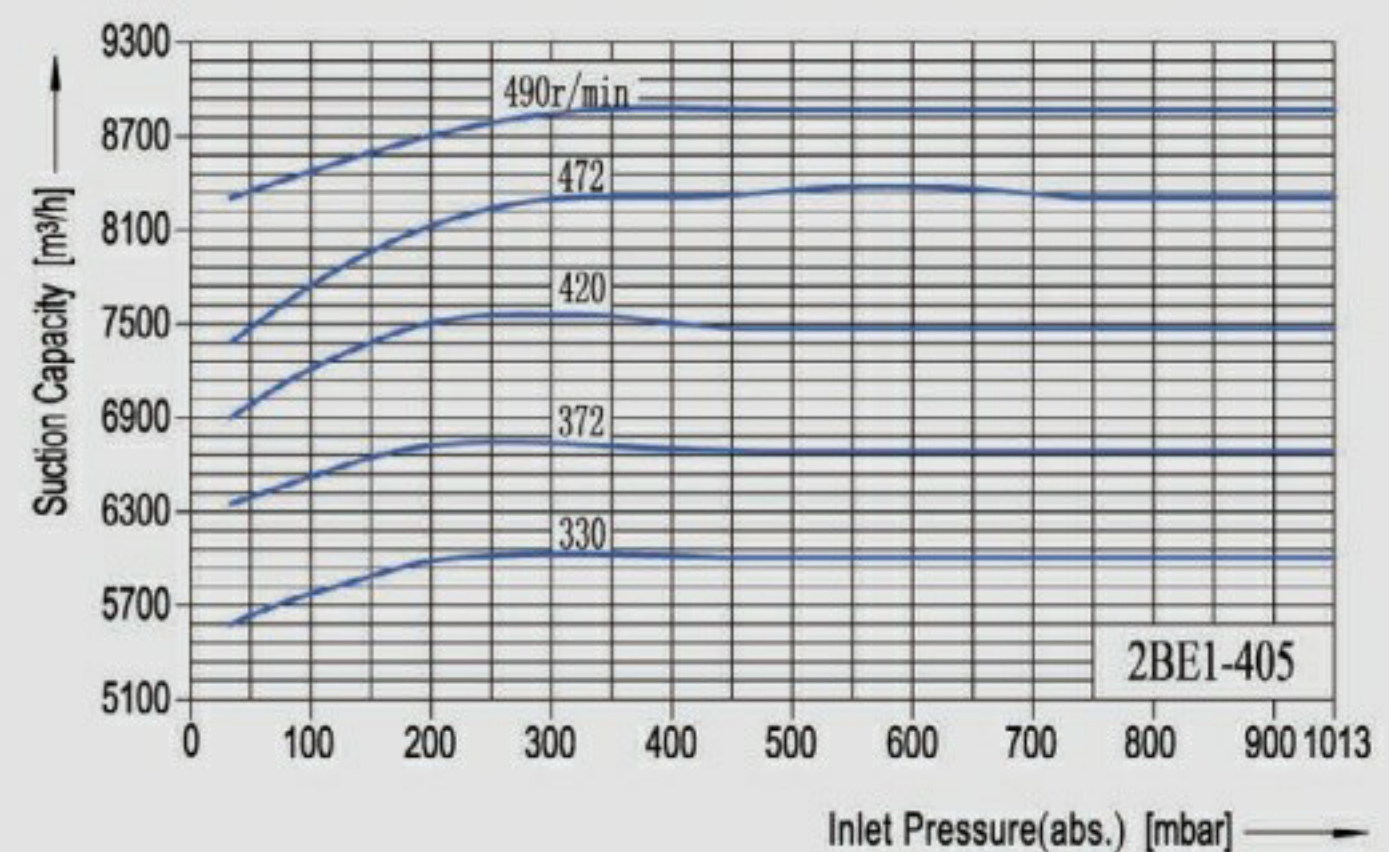

## 2BE3-40

注：右图是吸气温度为 20°C，工作液温度为 15°C，出口压力为一个标准大气压(1013mbar)，吸入介质为饱和空气时泵的性能曲线，性能允差 ±10%

Note: the performance curve is obtained under the following condition: suction temperature 20°C, operating liquid 15°C; outlet pressure is 1 atmospheric pressure (1013mbar); inlet medium is saturated air; tolerance ±10%.

不同吸气压力下的工作液（水）流量 Working Liquid(water)Flow Volume of Different Suction Pressure					
mbar	200	250	300	350	400
m <sup>3</sup> /h	9.5	9.9	9.9	9.5	9.0
mbar	450	500	550	600	650
m <sup>3</sup> /h	8.7	7.9	7.5	6.6	6.0
mbar	700	750	800		
m <sup>3</sup> /h	5.3	4.7	4.2		

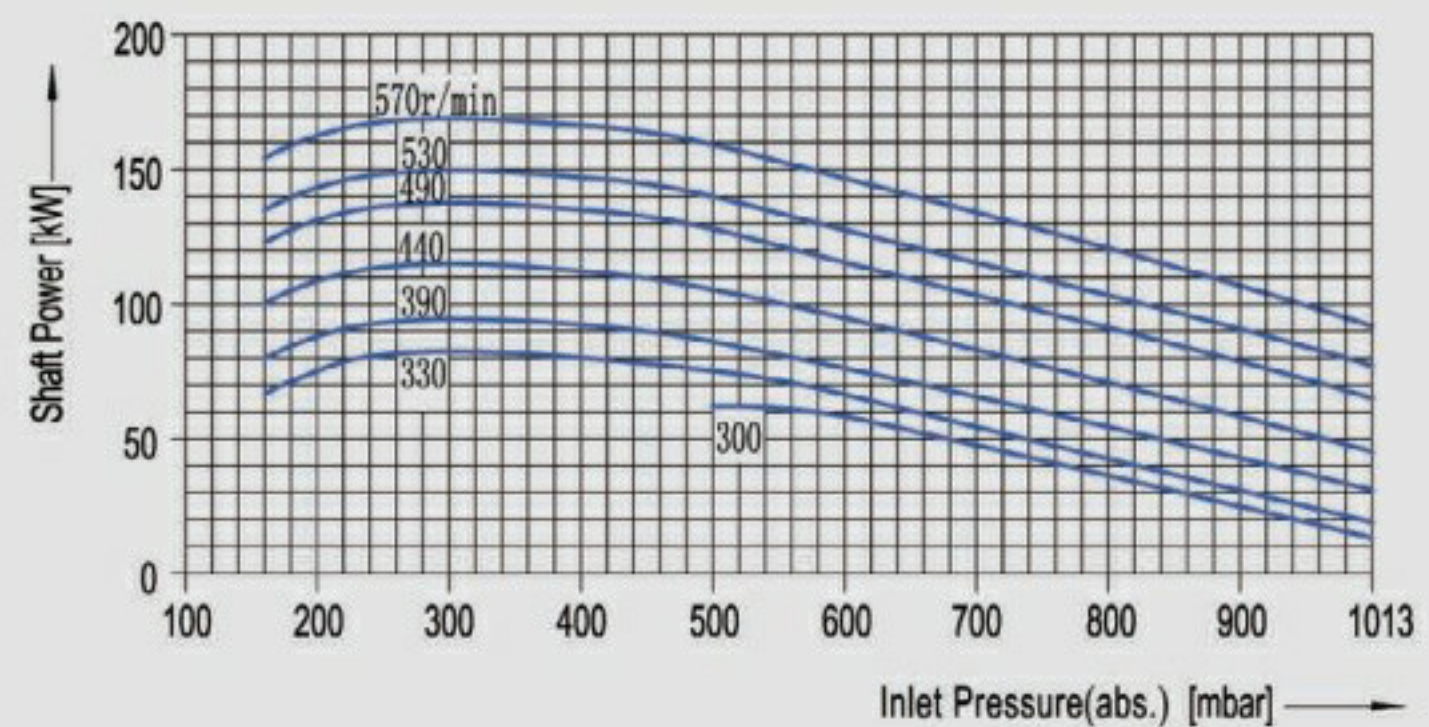
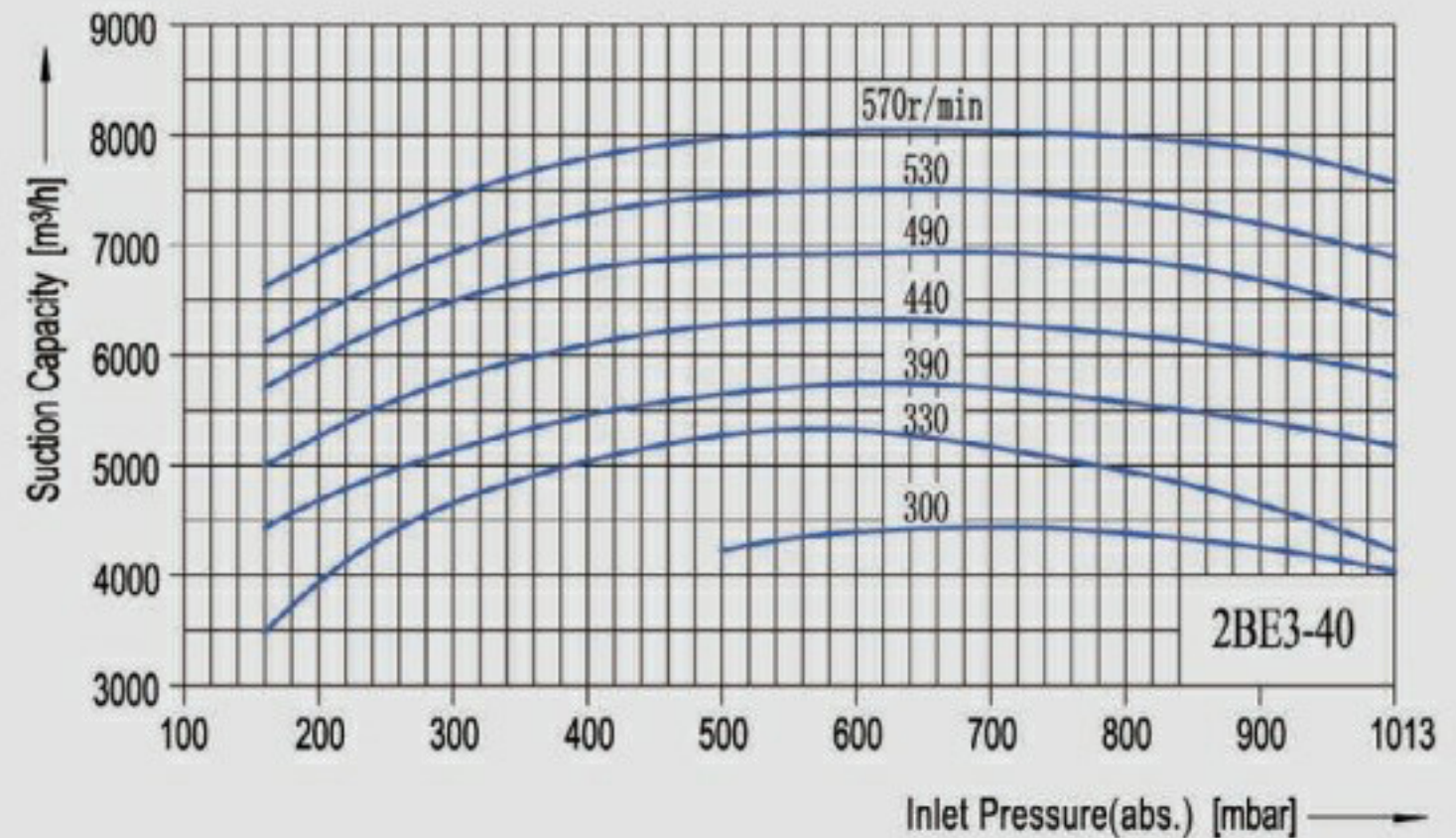

## 2BE3-42

注：右图是吸气温度为 20°C，工作液温度为 15°C，出口压力为一个标准大气压(1013mbar)，吸入介质为饱和空气时泵的性能曲线，性能允差 ±10%

Note: the performance curve is obtained under the following condition: suction temperature 20°C, operating liquid 15°C; outlet pressure is 1 atmospheric pressure (1013mbar); inlet medium is saturated air; tolerance ±10%.

不同吸气压力下的工作液（水）流量 Working Liquid(water)Flow Volume of Different Suction Pressure					
mbar	200	250	300	350	400
m <sup>3</sup> /h	13.0	13.5	13.5	12.9	12.3
mbar	450	500	550	600	650
m <sup>3</sup> /h	11.5	10.7	9.7	9.0	8.1
mbar	700	750	800		
m <sup>3</sup> /h	7.3	6.4	5.8		

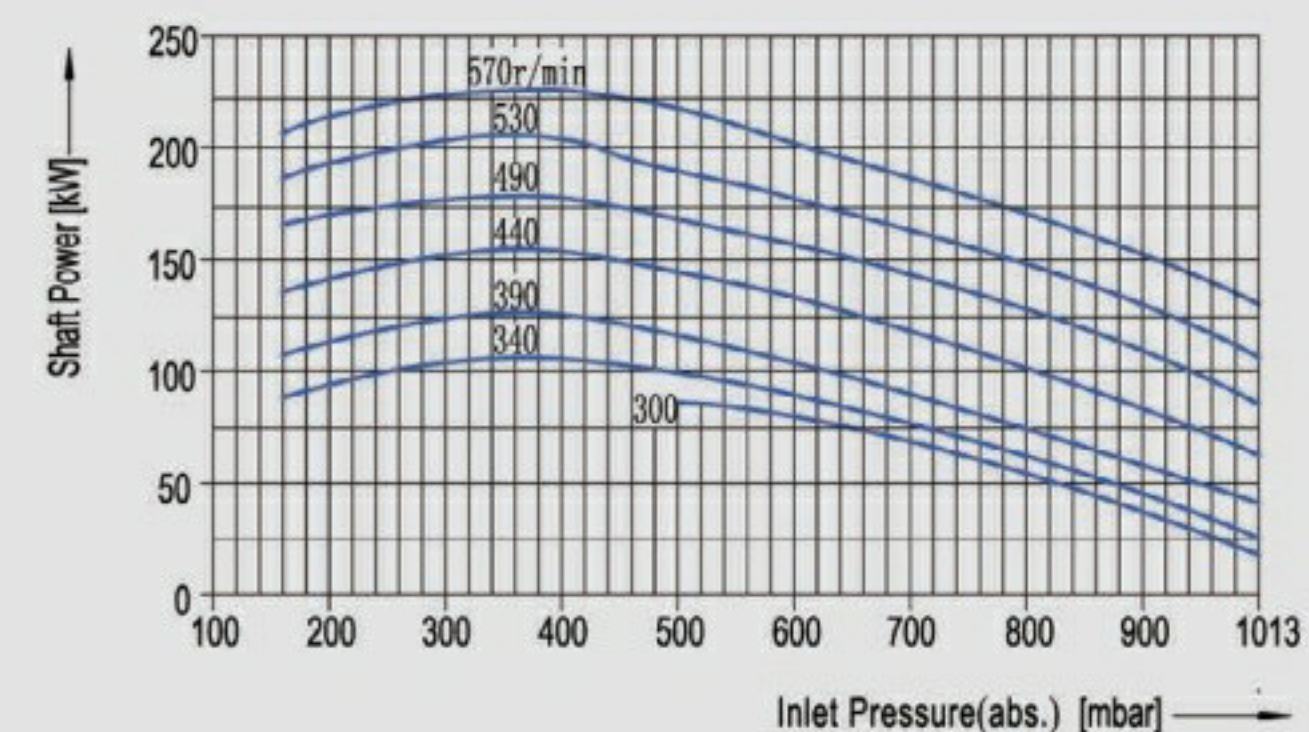
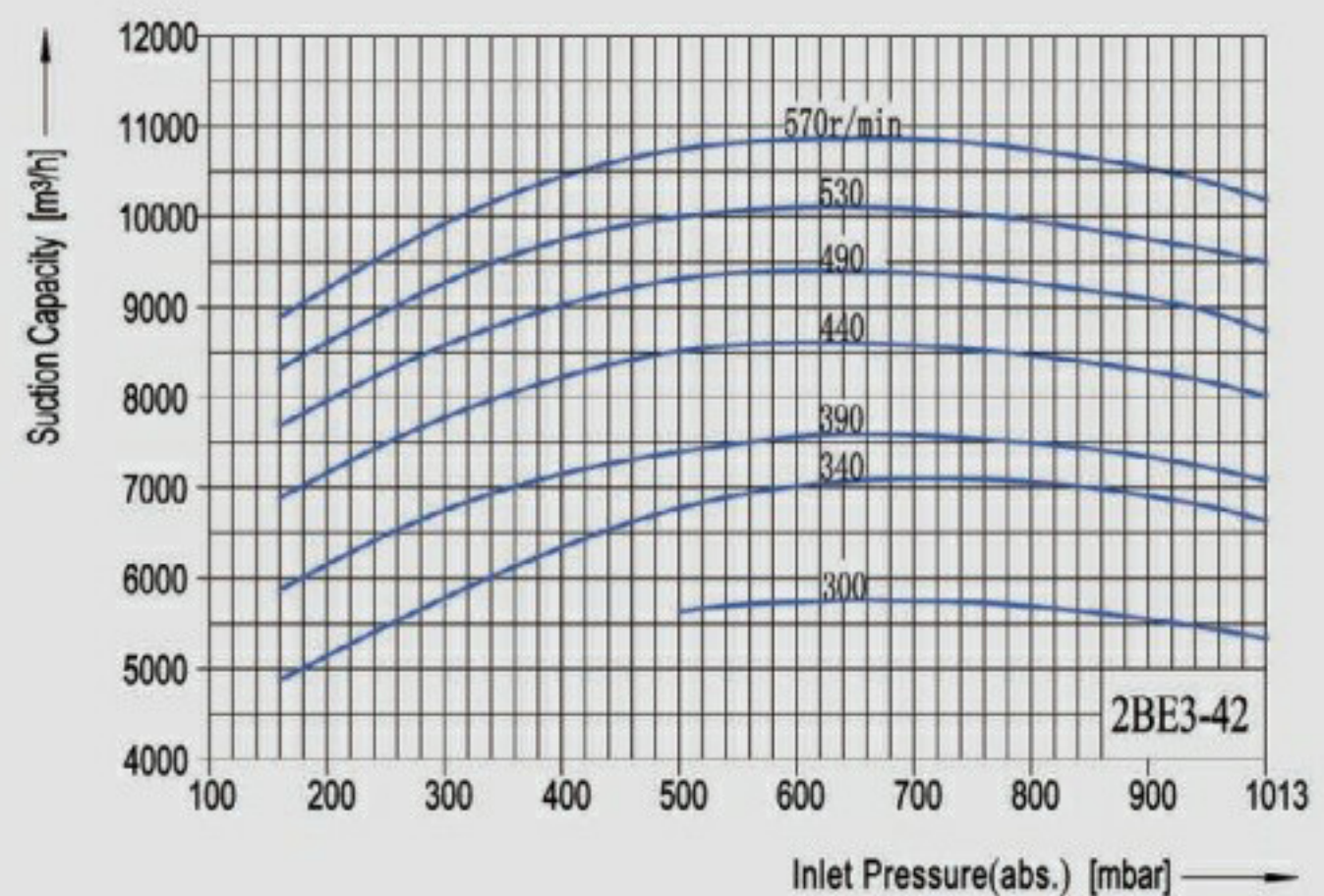

## 2BE3-50

注：右图是吸气温度为 20°C，工作液温度为 15°C，出口压力为一个标准大气压(1013mbar)，吸入介质为饱和空气时泵的性能曲线，性能允差 ±10%

Note: the performance curve is obtained under the following condition: suction temperature 20°C, operating liquid 15°C; outlet pressure is 1 atmospheric pressure (1013mbar); inlet medium is saturated air; tolerance ±10%.

不同吸气压力下的工作液（水）流量 Working Liquid(water)Flow Volume of Different Suction Pressure					
mbar	200	250	300	350	400
m <sup>3</sup> /h	17.6	18.3	18.3	17.2	16.6
mbar	450	500	550	600	650
m <sup>3</sup> /h	15.4	14.4	13.2	12.1	11.0
mbar	700	750	800		
m <sup>3</sup> /h	9.9	8.9	7.8		

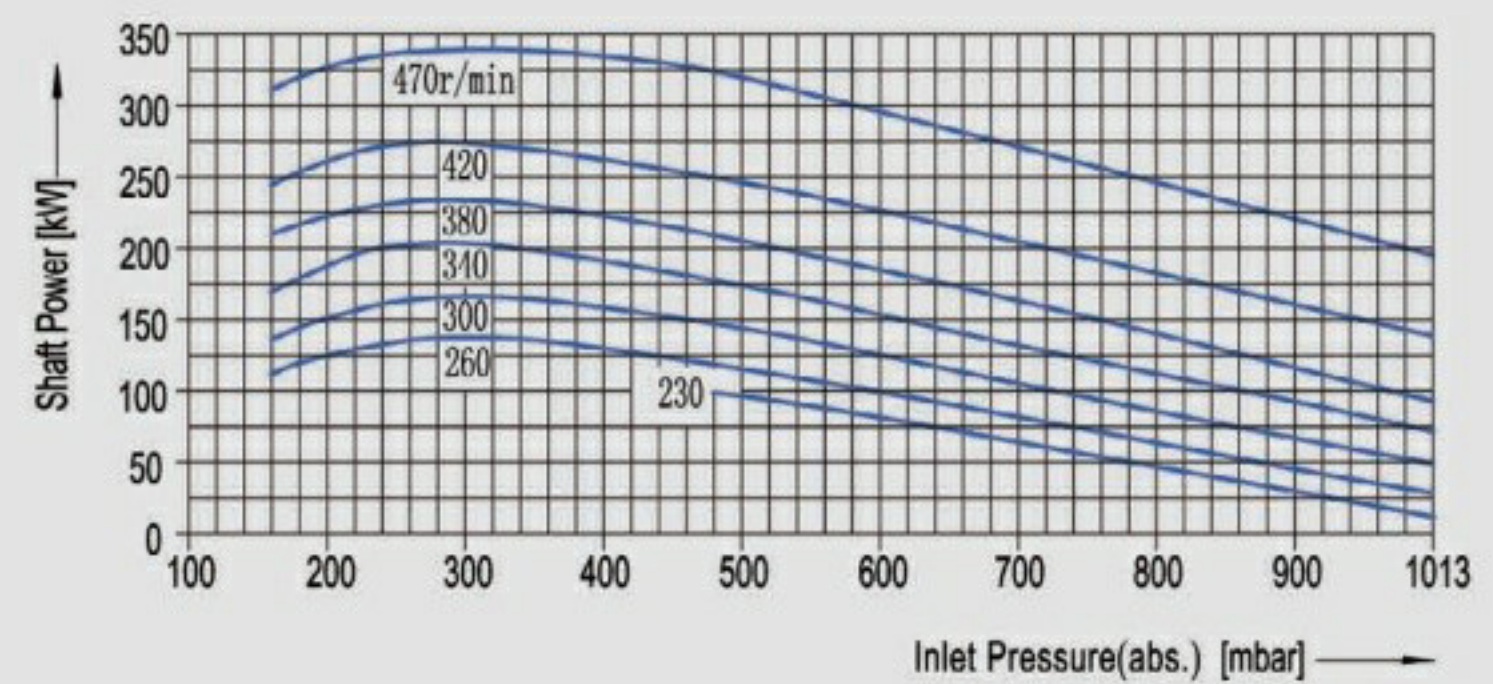
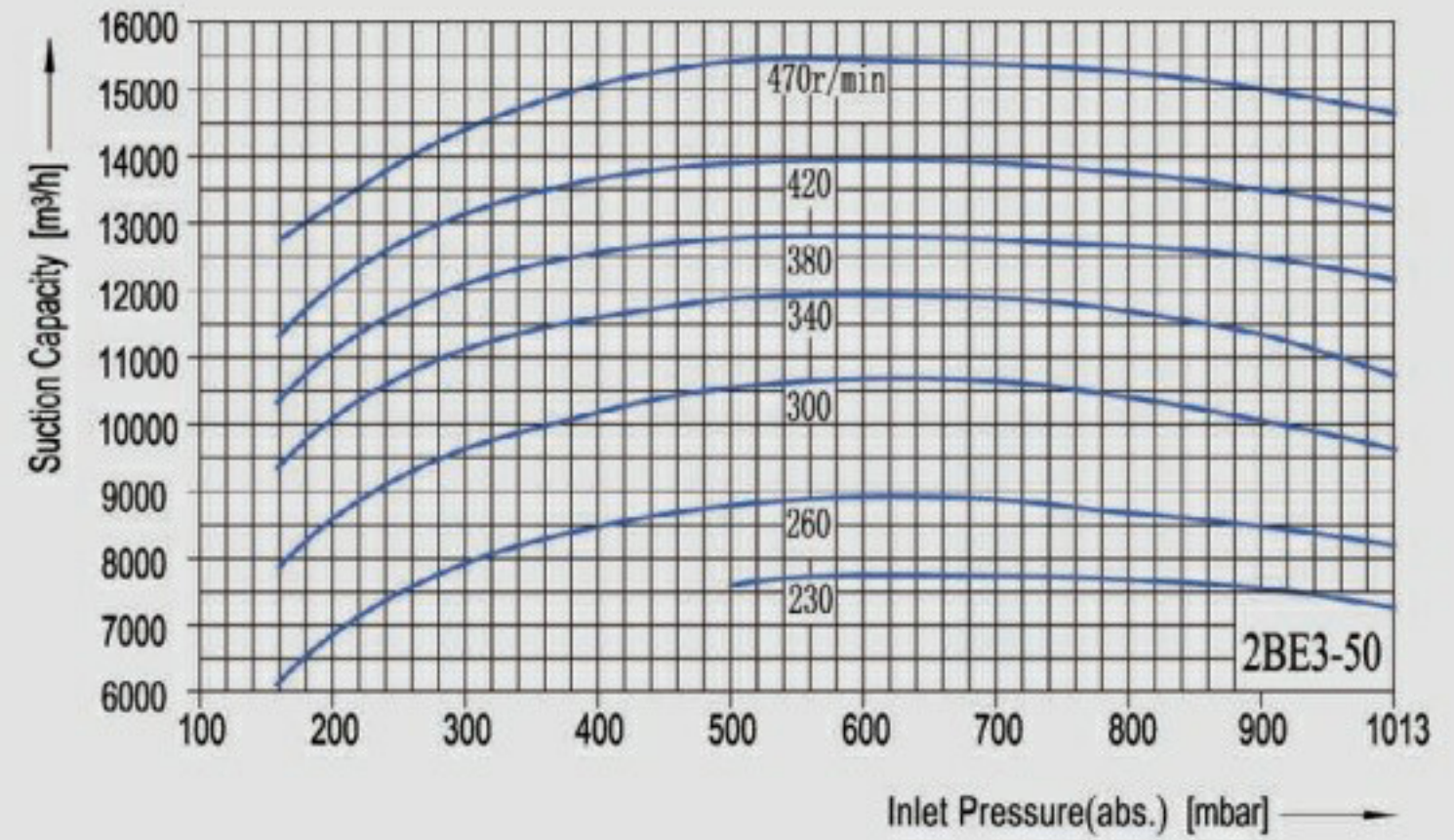

## 2BE3-52

注：右图是吸气温度为 20°C，工作液温度为 15°C，出口压力为一个标准大气压(1013mbar)，吸入介质为饱和空气时泵的性能曲线，性能允差 ±10%

Note: the performance curve is obtained under the following condition: suction temperature 20°C, operating liquid 15°C; outlet pressure is 1 atmospheric pressure (1013mbar); inlet medium is saturated air; tolerance ±10%.

不同吸气压力下的工作液（水）流量 Working Liquid(water)Flow Volume of Different Suction Pressure					
mbar	200	250	300	350	400
m <sup>3</sup> /h	21.5	22.2	22.2	21.2	20.2
mbar	450	500	550	600	650
m <sup>3</sup> /h	18.9	17.6	16.1	14.8	13.4
mbar	700	750	800		
m <sup>3</sup> /h	12.0	10.7	9.5		

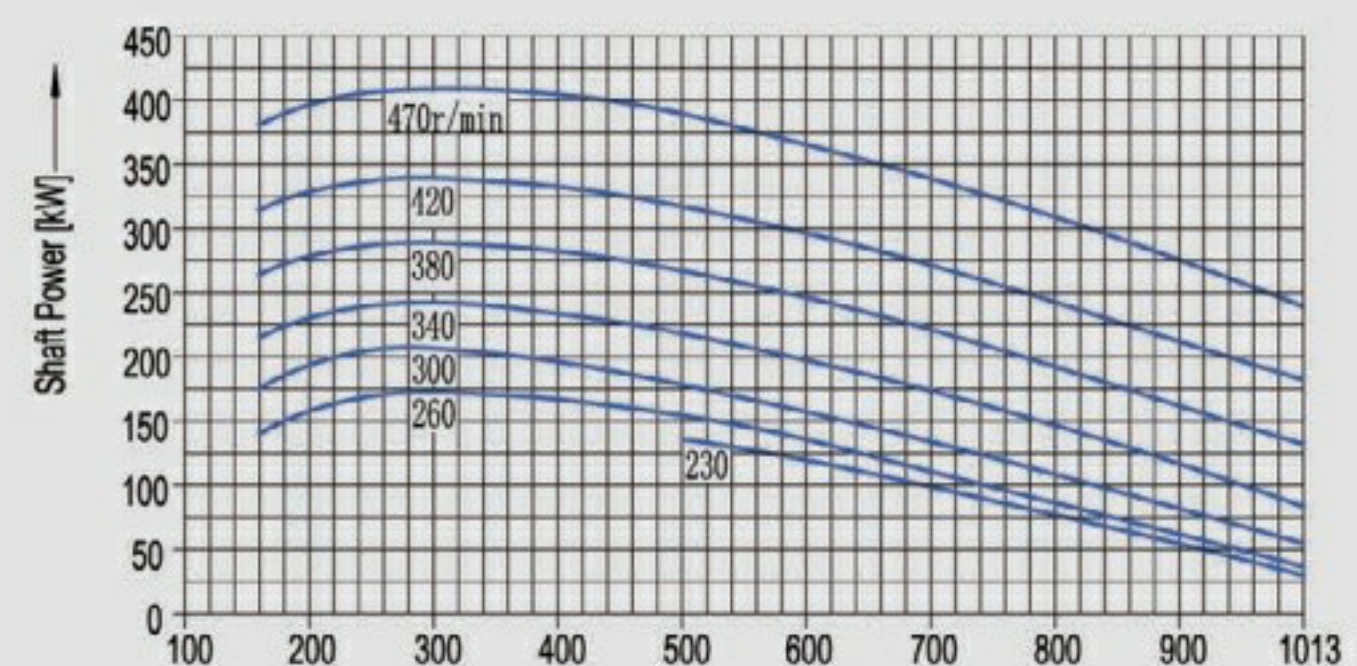
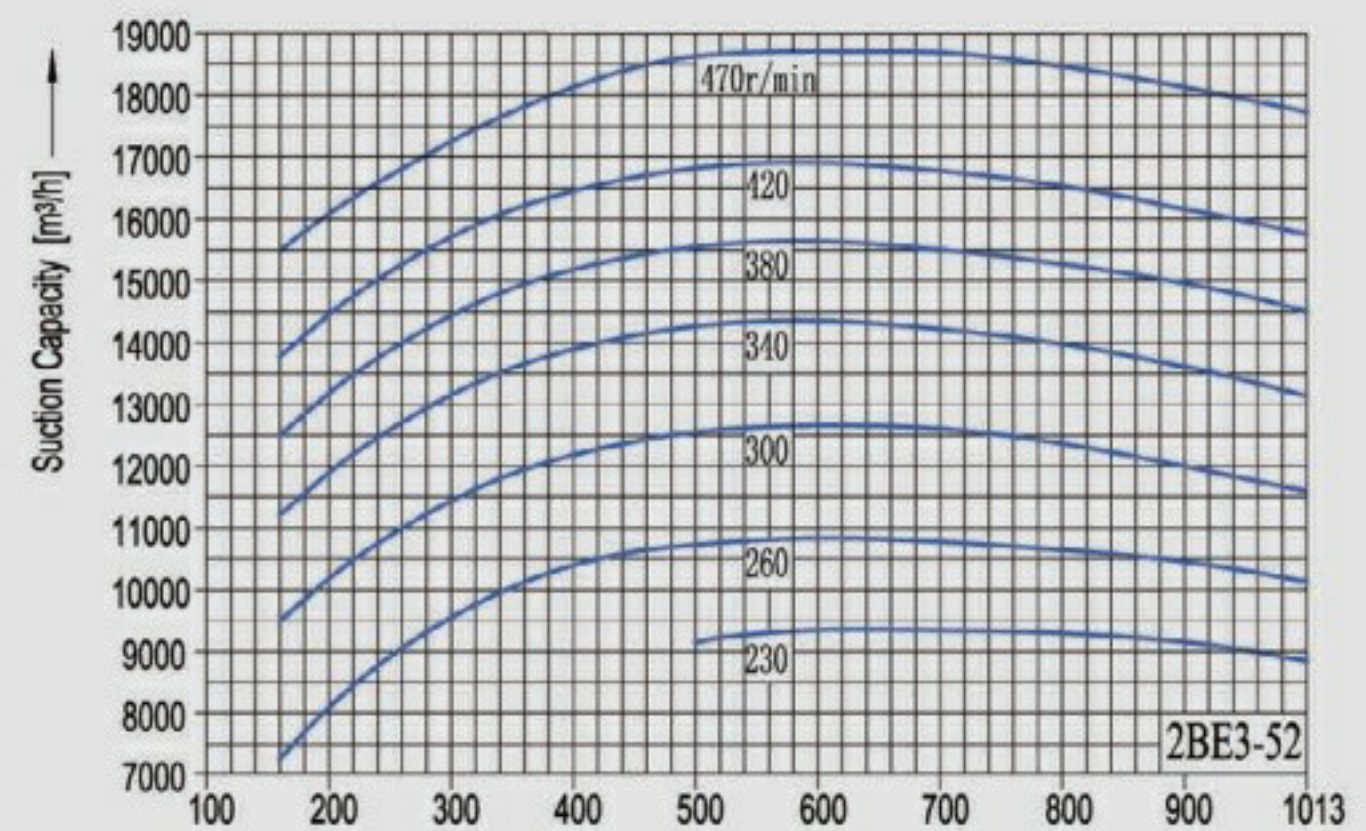

## 2BE3-60

注：右图是吸气温度为 20°C，工作液温度为 15°C，出口压力为一个标准大气压(1013mbar)，吸入介质为饱和空气时泵的性能曲线，性能允差 ±10%

Note: the performance curve is obtained under the following condition: suction temperature 20°C, operating liquid 15°C; outlet pressure is 1 atmospheric pressure (1013mbar); inlet medium is saturated air; tolerance ±10%.

不同吸气压力下的工作液（水）流量 Working Liquid(water)Flow Volume of Different Suction Pressure					
mbar	200	250	300	350	400
m <sup>3</sup> /h	24.6	25.4	25.4	24.2	23.0
mbar	450	500	550	600	650
m <sup>3</sup> /h	21.5	20.1	18.4	16.9	15.3
mbar	700	750	800		
m <sup>3</sup> /h	13.7	12.2	10.9		

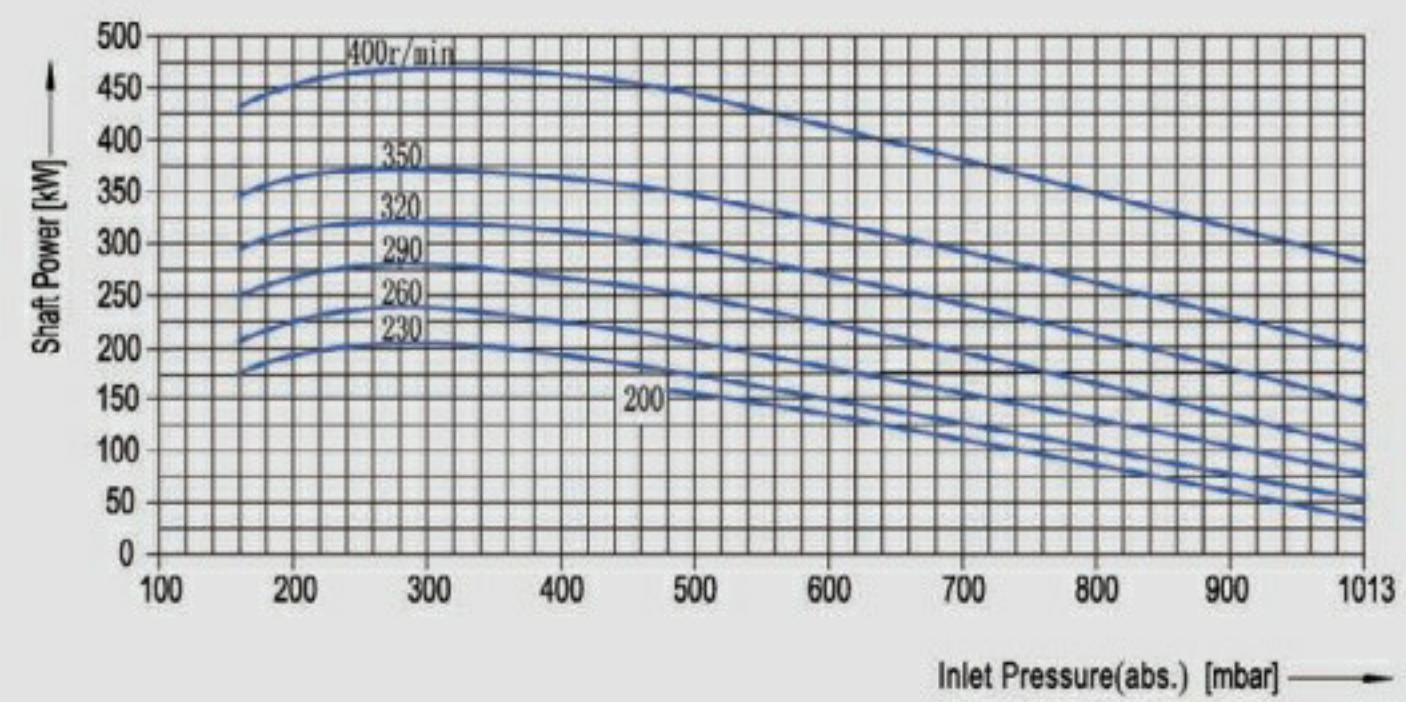
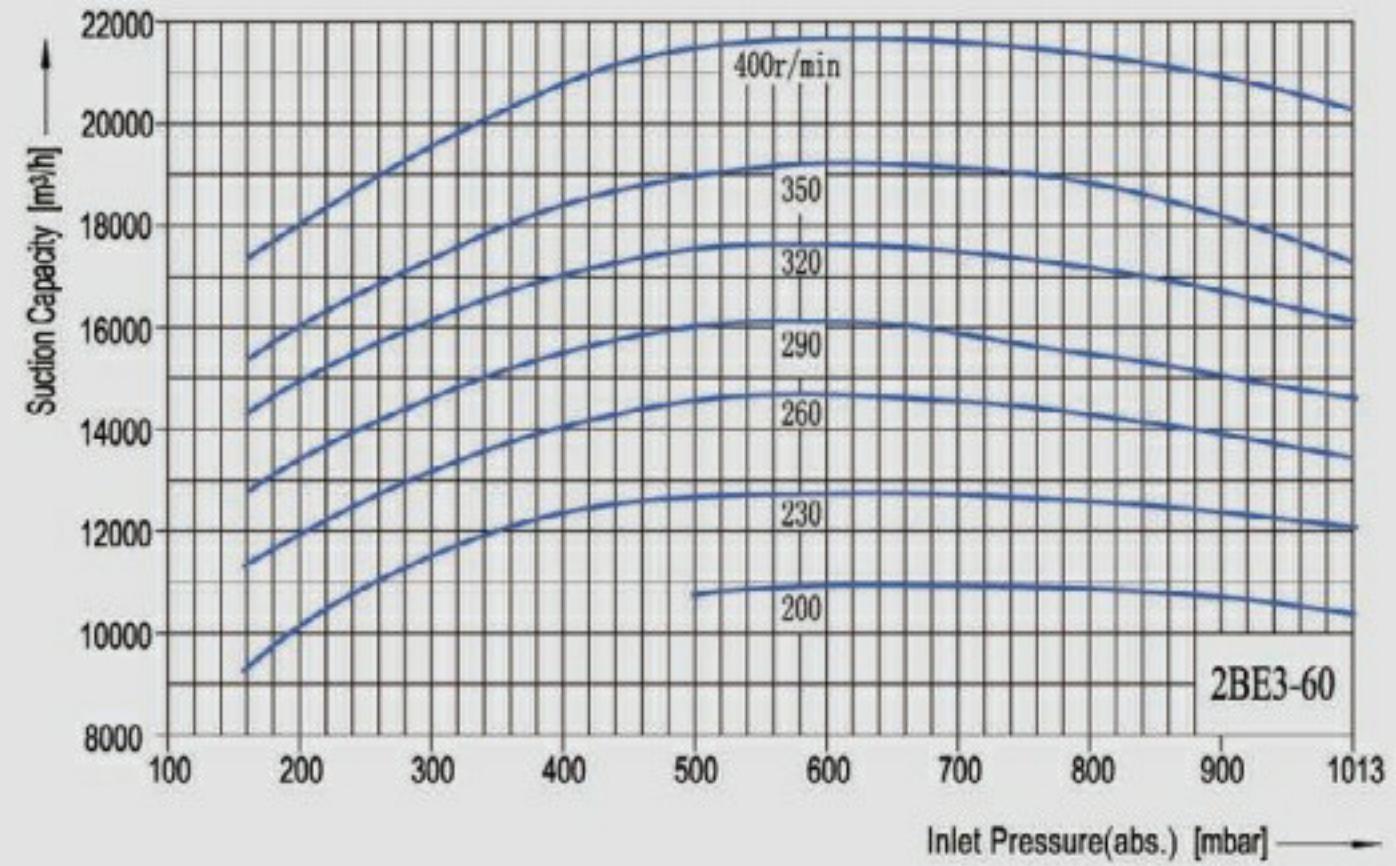

## 2BE3-62

注：右图是吸气温度为 20°C，工作液温度为 15°C，出口压力为一个标准大气压(1013mbar)，吸入介质为饱和空气时泵的性能曲线，性能允差 ±10%

Note: the performance curve is obtained under the following condition: suction temperature 20°C, operating liquid 15°C; outlet pressure is 1 atmospheric pressure (1013mbar); inlet medium is saturated air; tolerance ±10%.

不同吸气压力下的工作液（水）流量 Working Liquid(water)Flow Volume of Different Suction Pressure					
mbar	200	250	300	350	400
m <sup>3</sup> /h	30.0	30.9	30.9	29.3	28.0
mbar	450	500	550	600	650
m <sup>3</sup> /h	26.1	24.4	22.3	20.5	18.6
mbar	700	750	800		
m <sup>3</sup> /h	16.7	14.9	13.2		

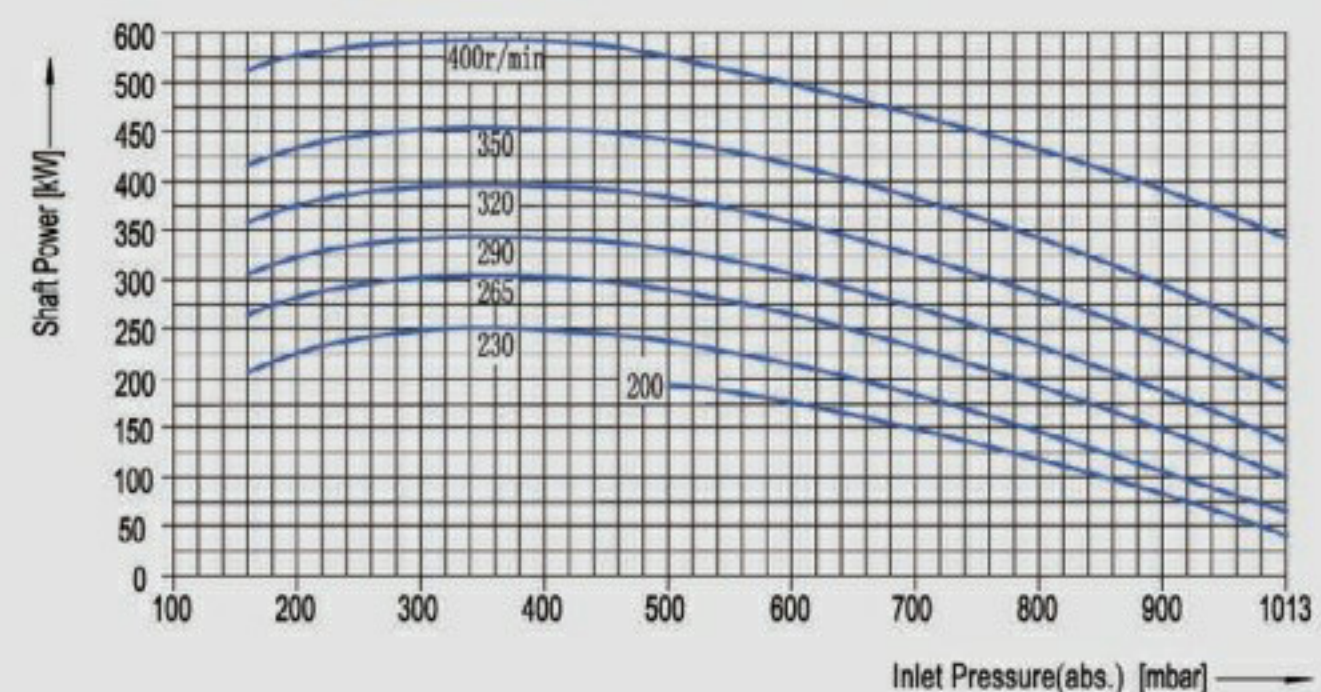
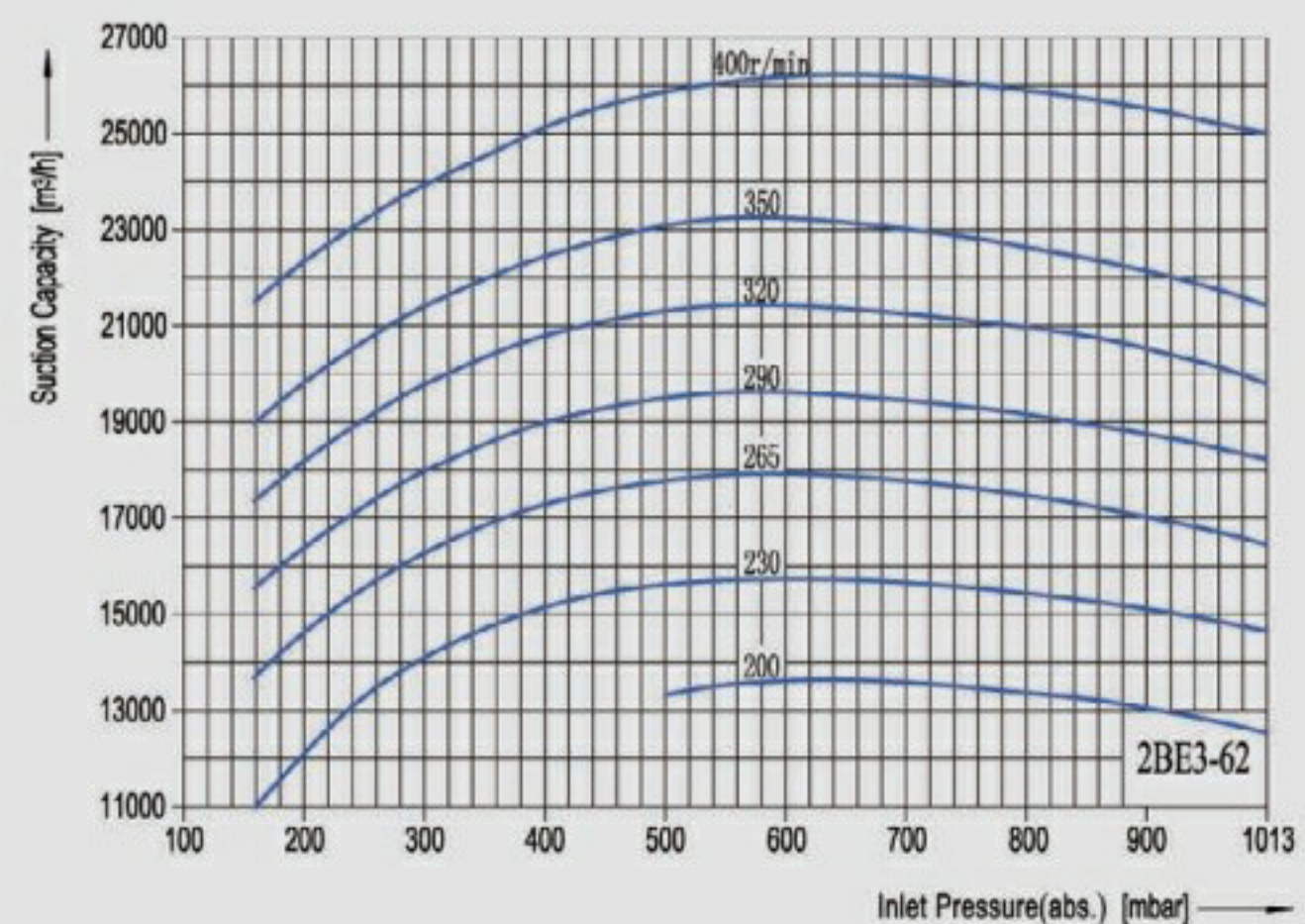

## 2BE3-67

注：右图是吸气温度为 20°C，工作液温度为 15°C，出口压力为一个标准大气压(1013mbar)，吸入介质为饱和空气时泵的性能曲线，性能允差 ±10%

Note: the performance curve is obtained under the following condition: suction temperature 20°C, operating liquid 15°C; outlet pressure is 1 atmospheric pressure (1013mbar); inlet medium is saturated air; tolerance ±10%.

不同吸气压力下的工作液（水）流量 Working Liquid(water)Flow Volume of Different Suction Pressure					
mbar	200	250	300	350	400
m <sup>3</sup> /h	34.6	35.5	36.4	34.6	33.0
mbar	450	500	550	600	650
m <sup>3</sup> /h	30.7	28.7	26.3	24.1	21.8
mbar	700	750	800		
m <sup>3</sup> /h	19.7	17.6	15.5		

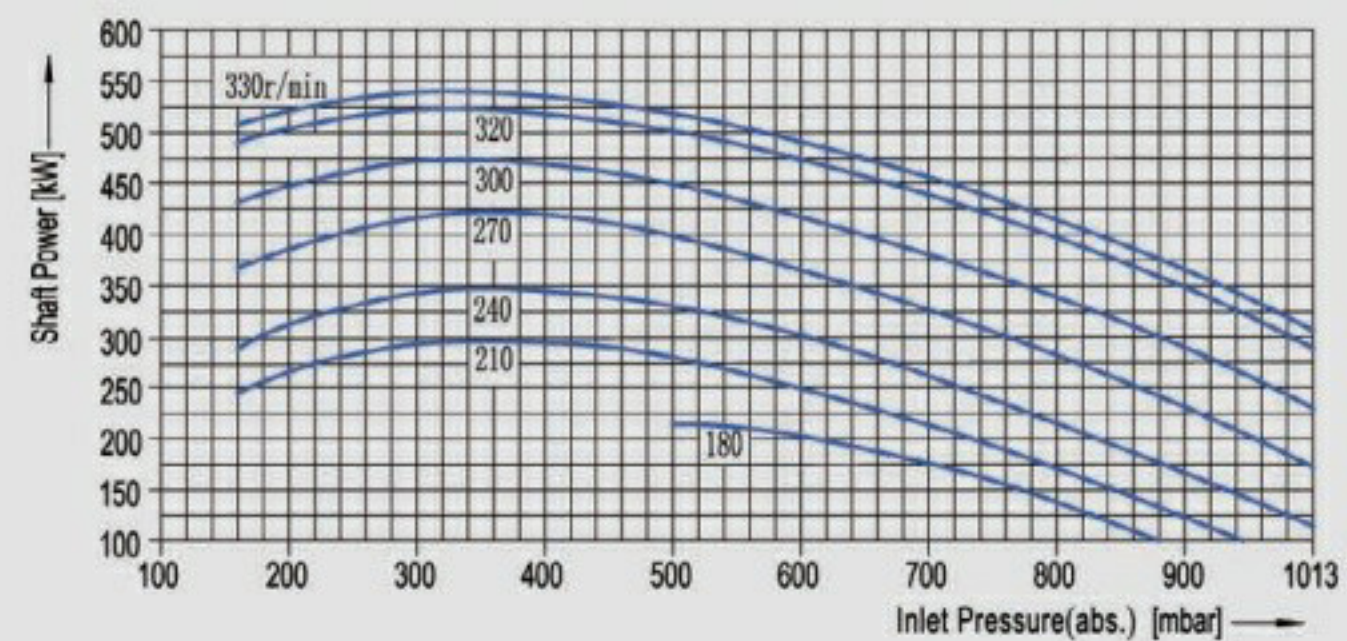
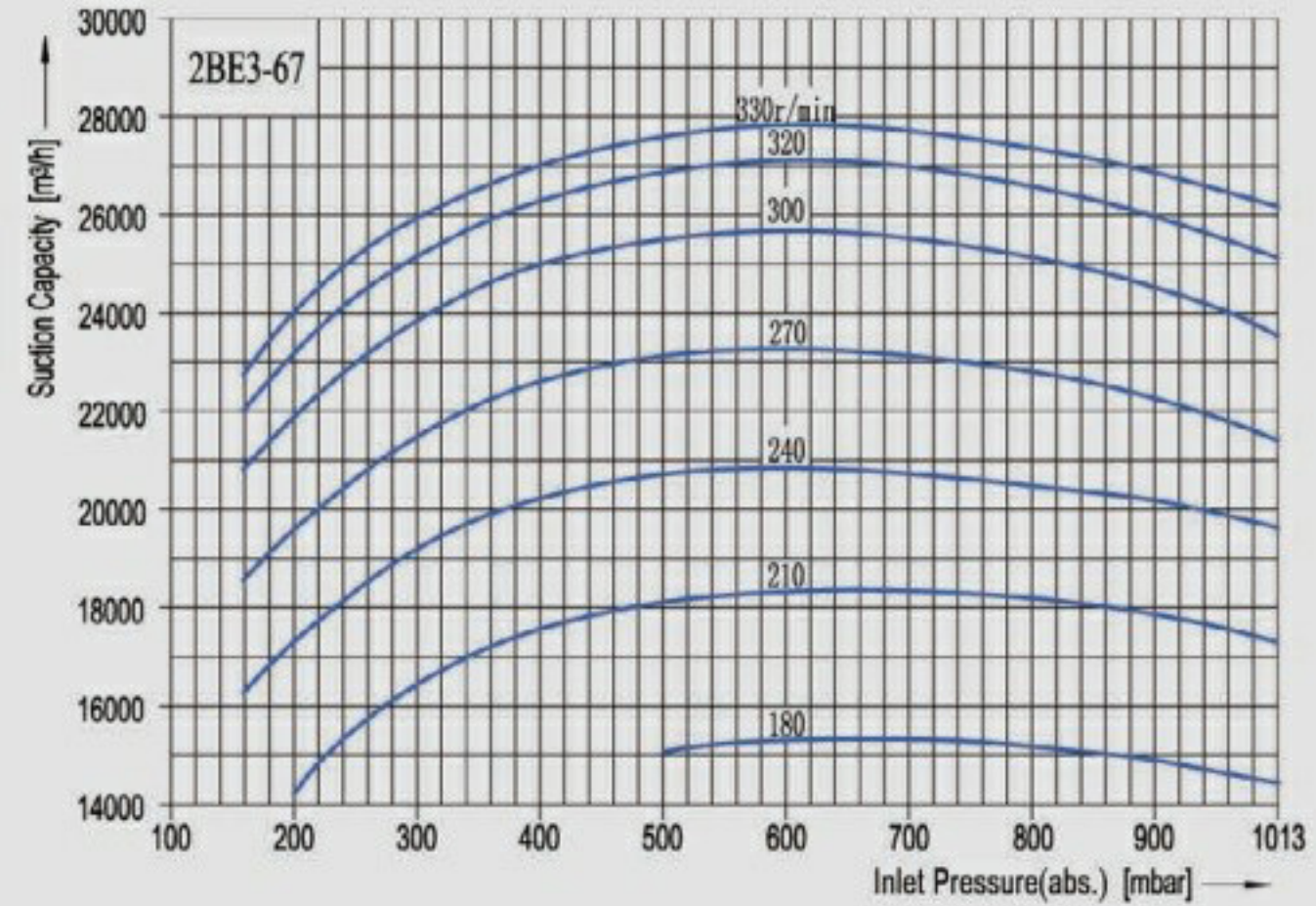

## 2BE3-72

注：右图是吸气温度为 20°C，工作液温度为 15°C，出口压力为一个标准大气压(1013mbar)，吸入介质为饱和空气时泵的性能曲线，性能允差 ±10%

Note: the performance curve is obtained under the following condition: suction temperature 20°C, operating liquid 15°C; outlet pressure is 1 atmospheric pressure (1013mbar); inlet medium is saturated air; tolerance ±10%.

不同吸气压力下的工作液（水）流量 Working Liquid(water)Flow Volume of Different Suction Pressure					
mbar	200	250	300	350	400
m <sup>3</sup> /h	41.3	42.2	43.5	41.4	39.4
mbar	450	500	550	600	650
m <sup>3</sup> /h	36.7	34.3	31.5	28.8	26.2
mbar	700	750	800		
m <sup>3</sup> /h	23.7	21.1	18.6		

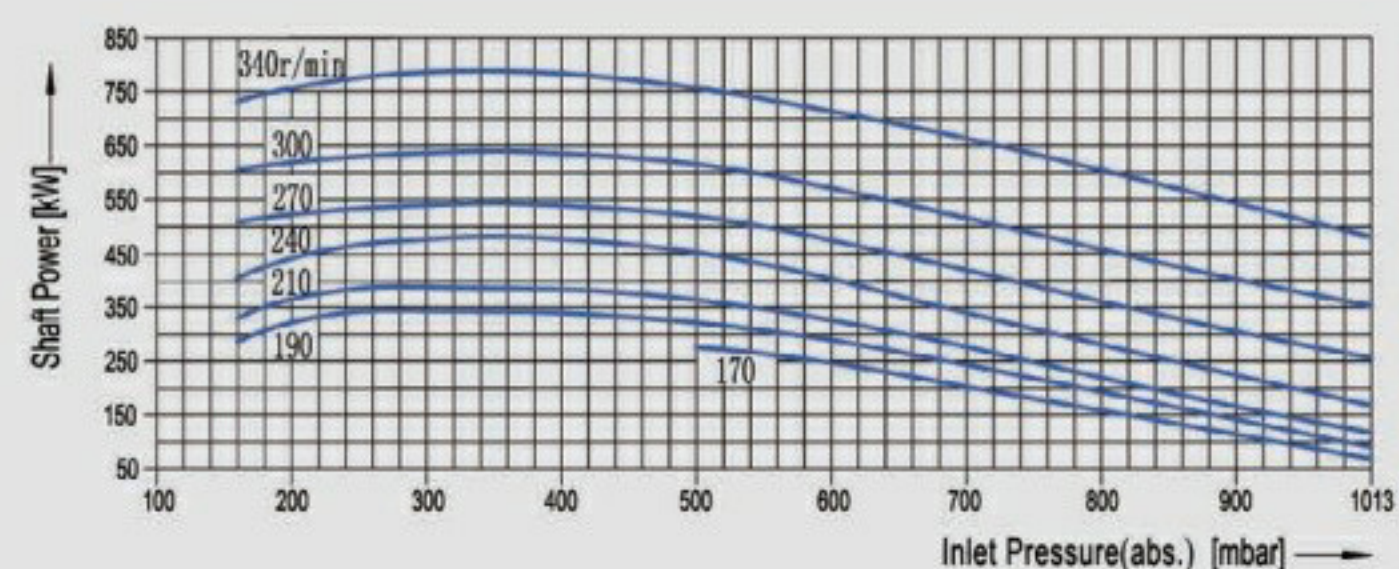
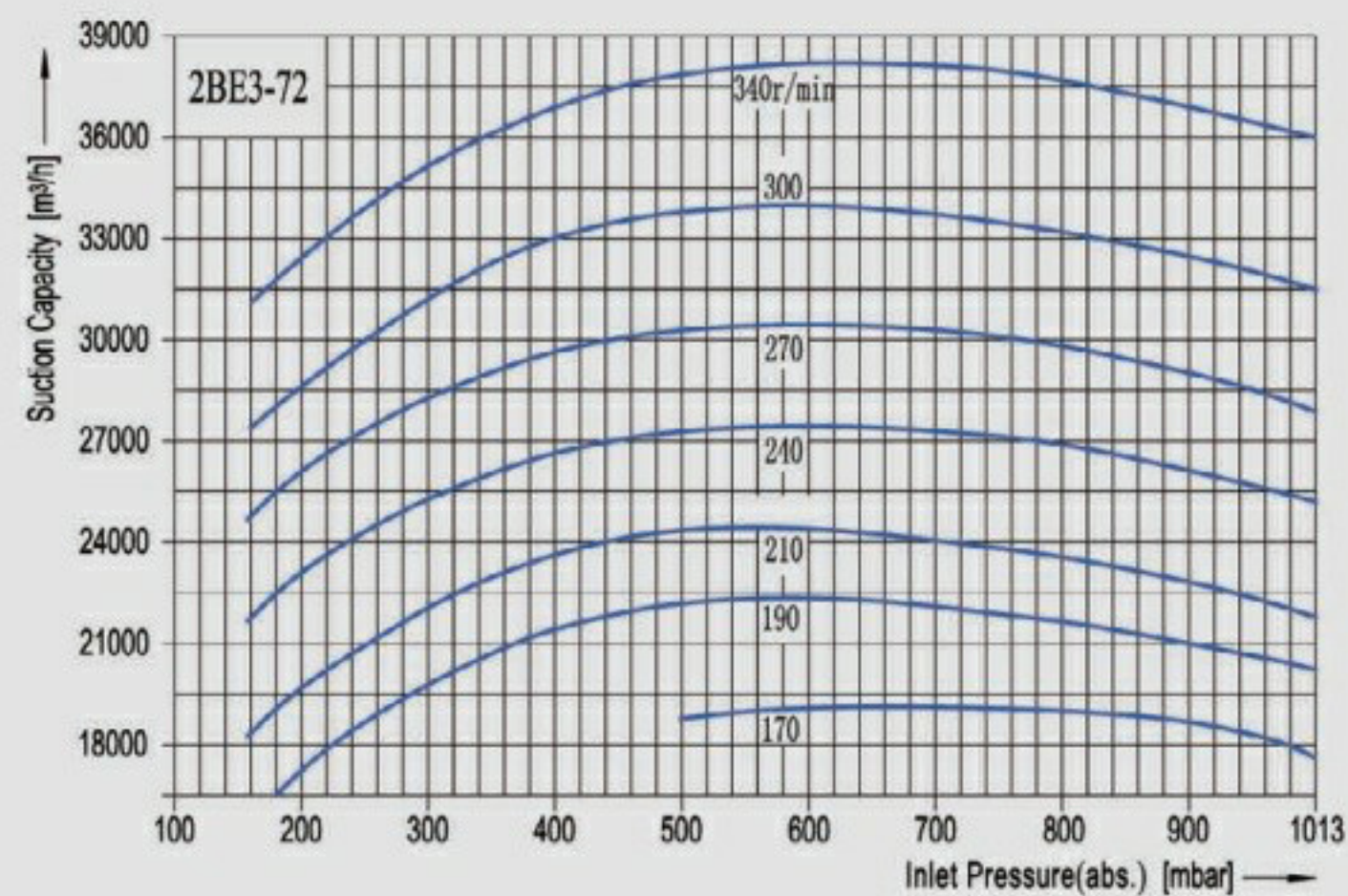

## 2BEN-80

注：右图是吸气温度为 20°C，工作液温度为 15°C，出口压力为一个标准大气压(1013mbar)，吸入介质为饱和空气时泵的性能曲线，性能允差 ±10%

Note: the performance curve is obtained under the following condition: suction temperature 20°C, operating liquid 15°C; outlet pressure is 1 atmospheric pressure (1013mbar); inlet medium is saturated air; tolerance ±10%.

不同吸气压力下的工作液（水）流量 Working Liquid(water)Flow Volume of Different Suction Pressure					
mbar	200	250	300	350	400
m <sup>3</sup> /h	58	60	62	58	54
mbar	450	500	550	600	650
m <sup>3</sup> /h	53	48	44	40	38
mbar	700	750	800		
m <sup>3</sup> /h	33	28	26		

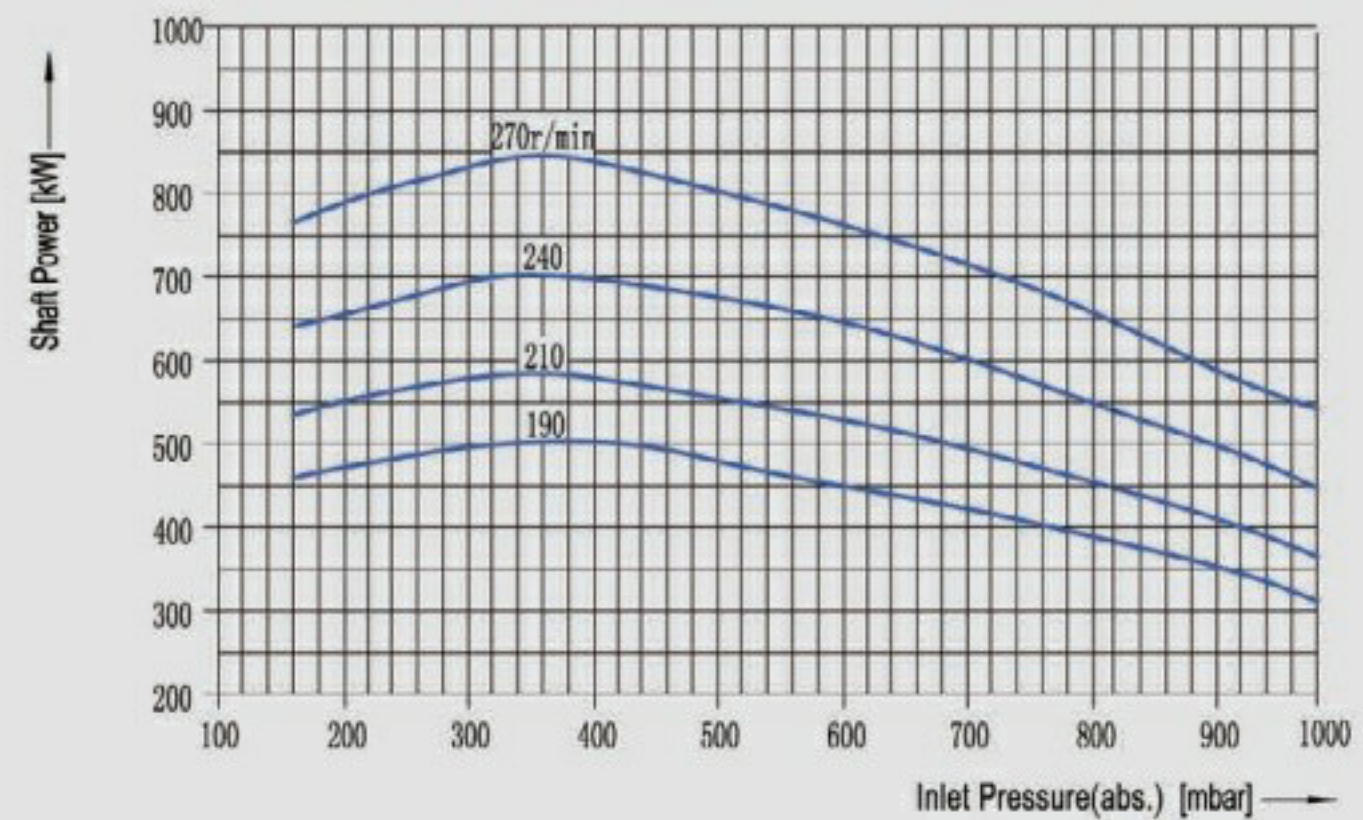
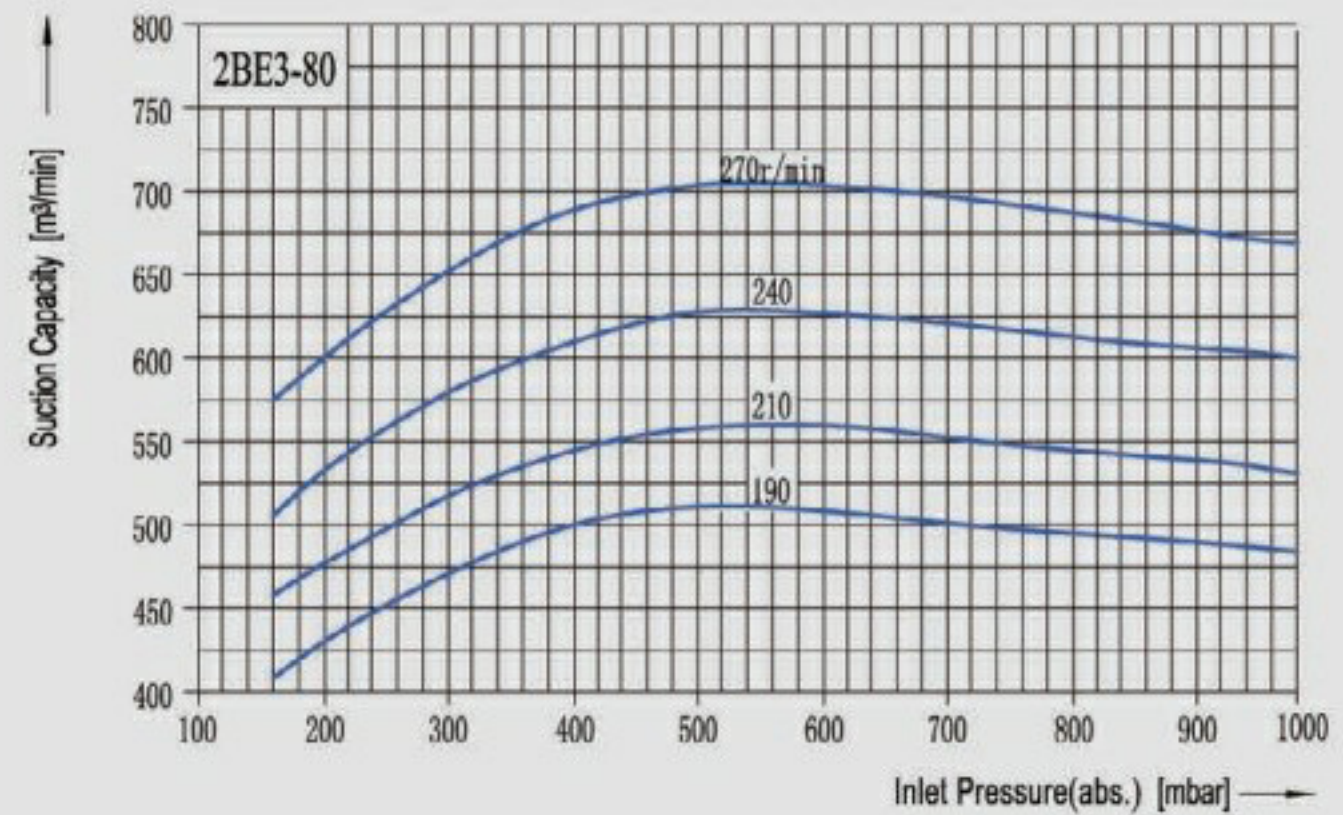

## 2BEN-90

注：右图是吸气温度为 20°C，工作液温度为 15°C，出口压力为一个标准大气压(1013mbar)，吸入介质为饱和空气时泵的性能曲线，性能允差 ±10%

Note: the performance curve is obtained under the following condition: suction temperature 20°C, operating liquid 15°C; outlet pressure is 1 atmospheric pressure (1013mbar); inlet medium is saturated air; tolerance ±10%.

不同吸气压力下的工作液（水）流量 Working Liquid(water)Flow Volume of Different Suction Pressure					
mbar	200	250	300	350	400
m <sup>3</sup> /h	63.6	64.9	67	63.8	60.7
mbar	450	500	550	600	650
m <sup>3</sup> /h	56.5	52.8	48.5	44.3	40.4
mbar	700	750	800		
m <sup>3</sup> /h	38.4	32.5	28.6		

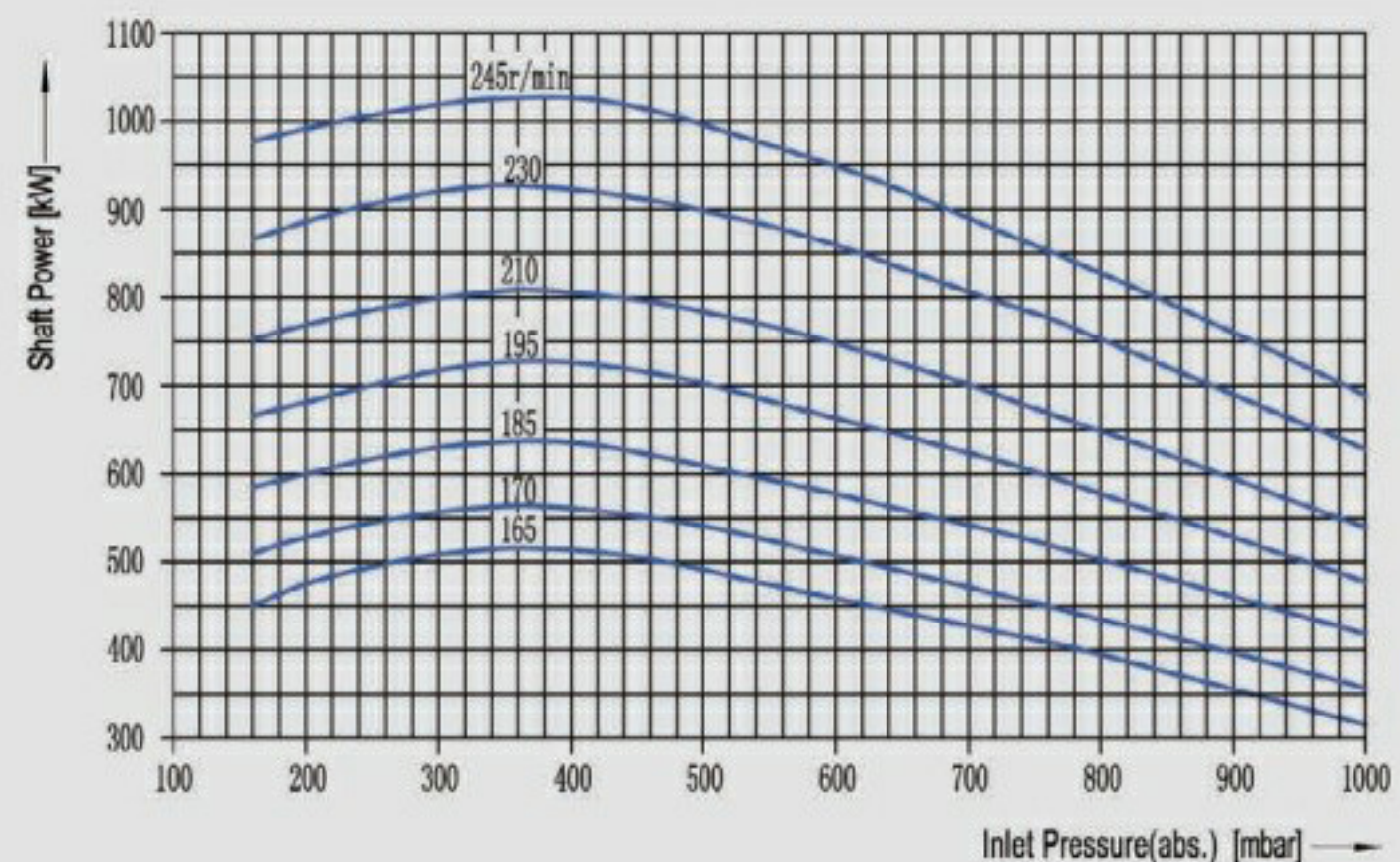
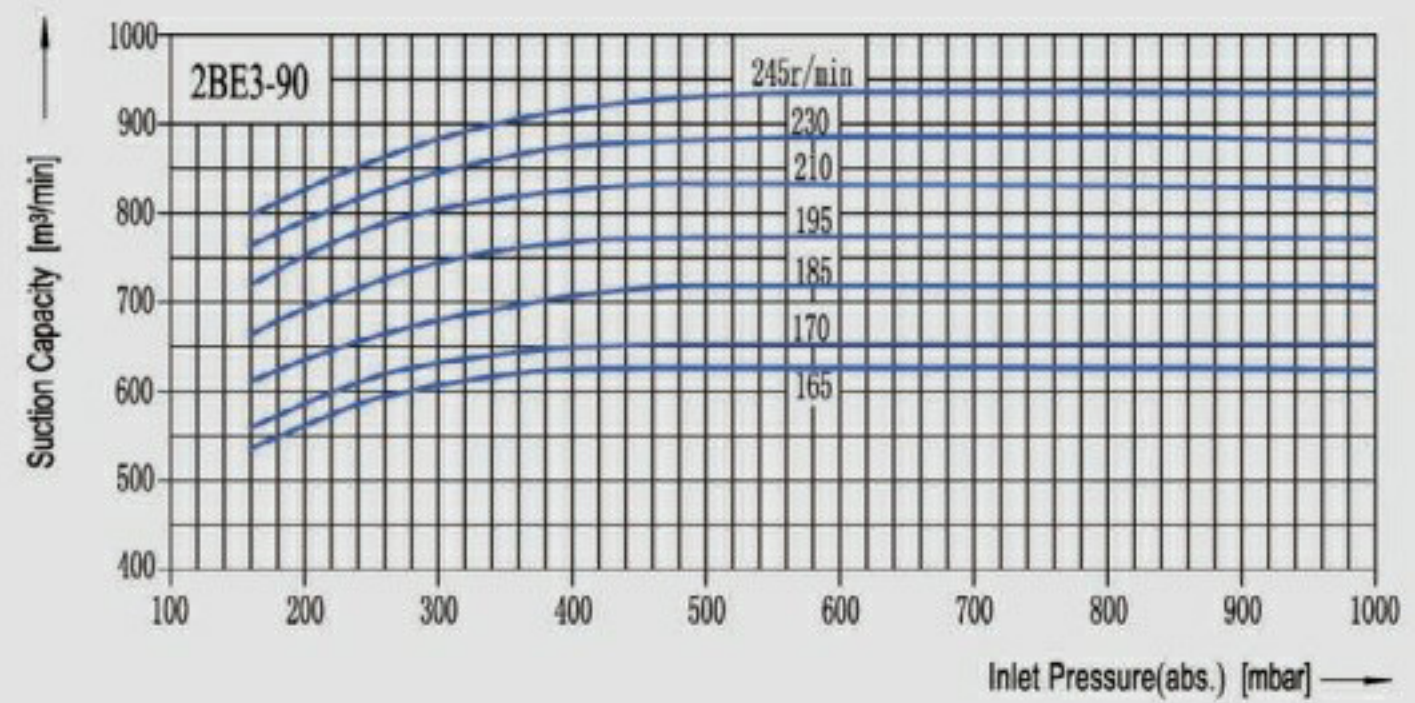

## 2BEN-100

注：右图是吸气温度为 20°C，工作液温度为 15°C，出口压力为一个标准大气压(1013mbar)，吸入介质为饱和空气时泵的性能曲线，性能允差 ±10%

Note: the performance curve is obtained under the following condition: suction temperature 20°C, operating liquid 15°C; outlet pressure is 1 atmospheric pressure (1013mbar); inlet medium is saturated air; tolerance ±10%.

不同吸气压力下的工作液（水）流量 Working Liquid(water).Flow Volume of Different Suction Pressure					
mbar	200	250	300	350	400
m <sup>3</sup> /h	84.4	86.1	88.9	84.7	80.6
mbar	450	500	550	600	650
m <sup>3</sup> /h	75.5	70.2	64.3	58.8	53.6
mbar	700	750	800		
m <sup>3</sup> /h	48.5	43.1	38.1		

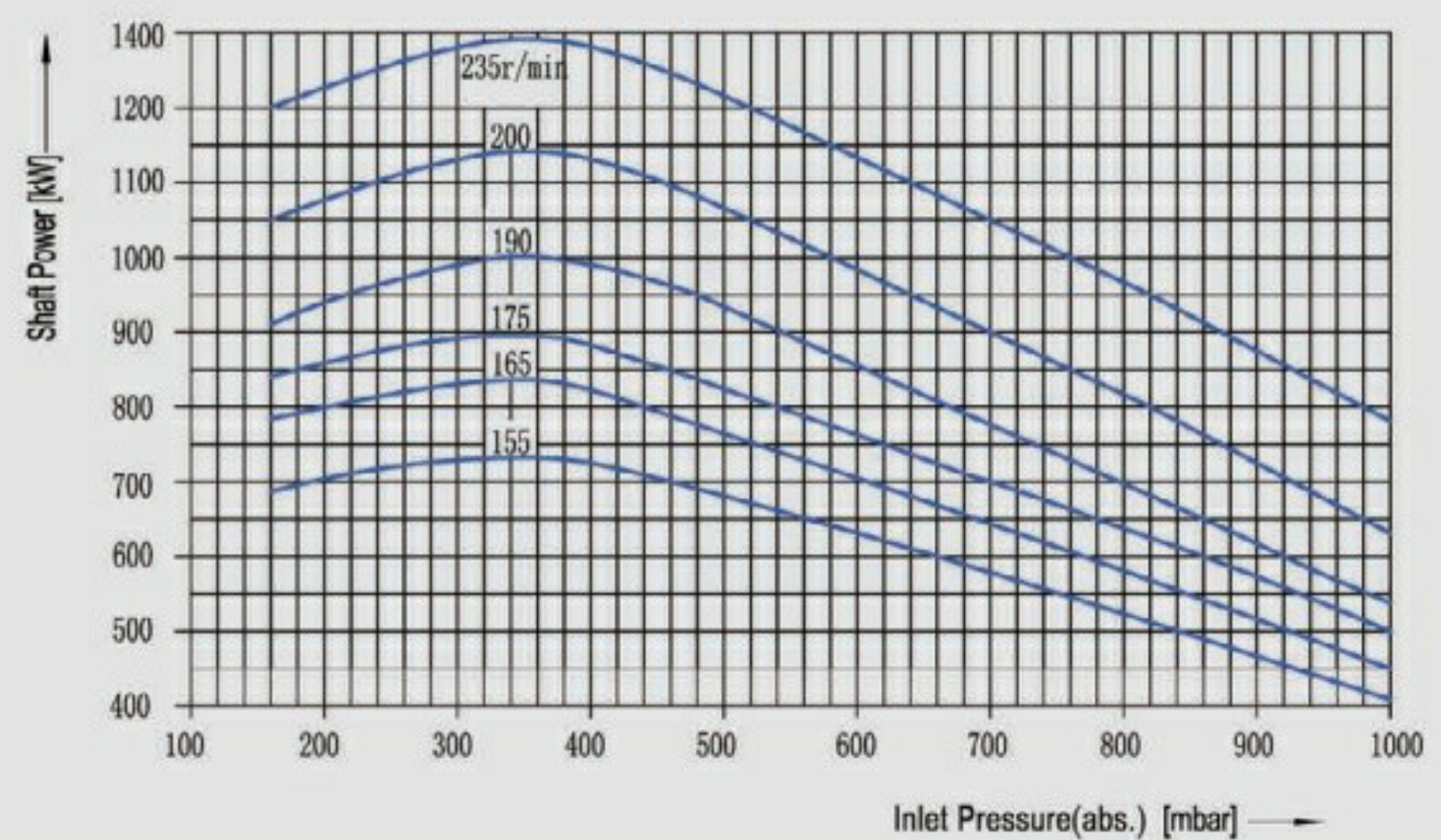
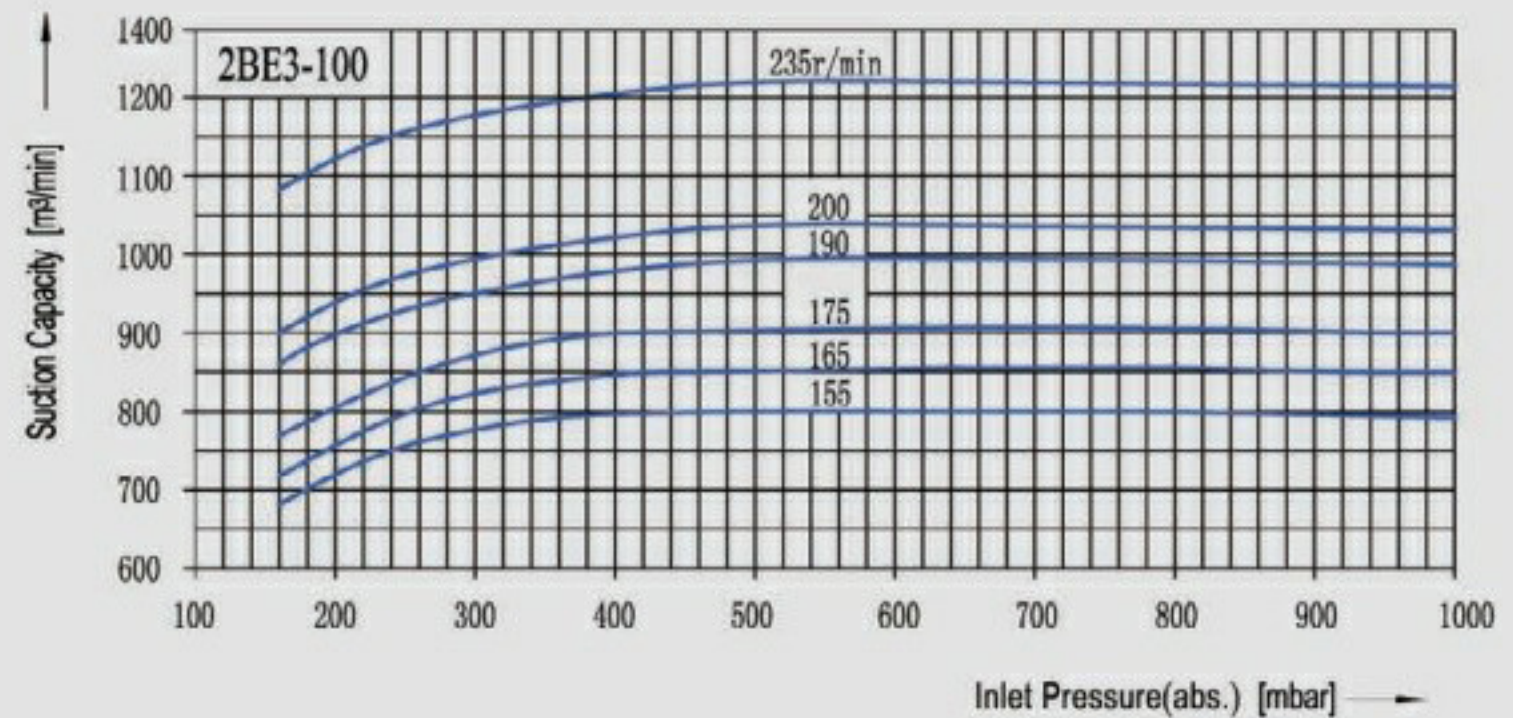

## 2BV-060

2BV 曲线说明：

注：1，该性能曲线是在吸入介质为 20°C 的饱和空气，排气压力为 101325mbar，工作液温度为 15°C 的状态下得到的。

2，性能允差 ±10%。

3，吸气曲线图中左侧为配用大气喷射泵的性能指标。

Note: the performance curve is obtained under the following condition:

suction medium: 20 °C saturated air;

operating liquid 15 °C;

outlet pressure: 1 atmospheric pressure(1013 mbar);

tolerance ±10%;

curve at beginning of suction capacity curve is obtained with gas ejector.

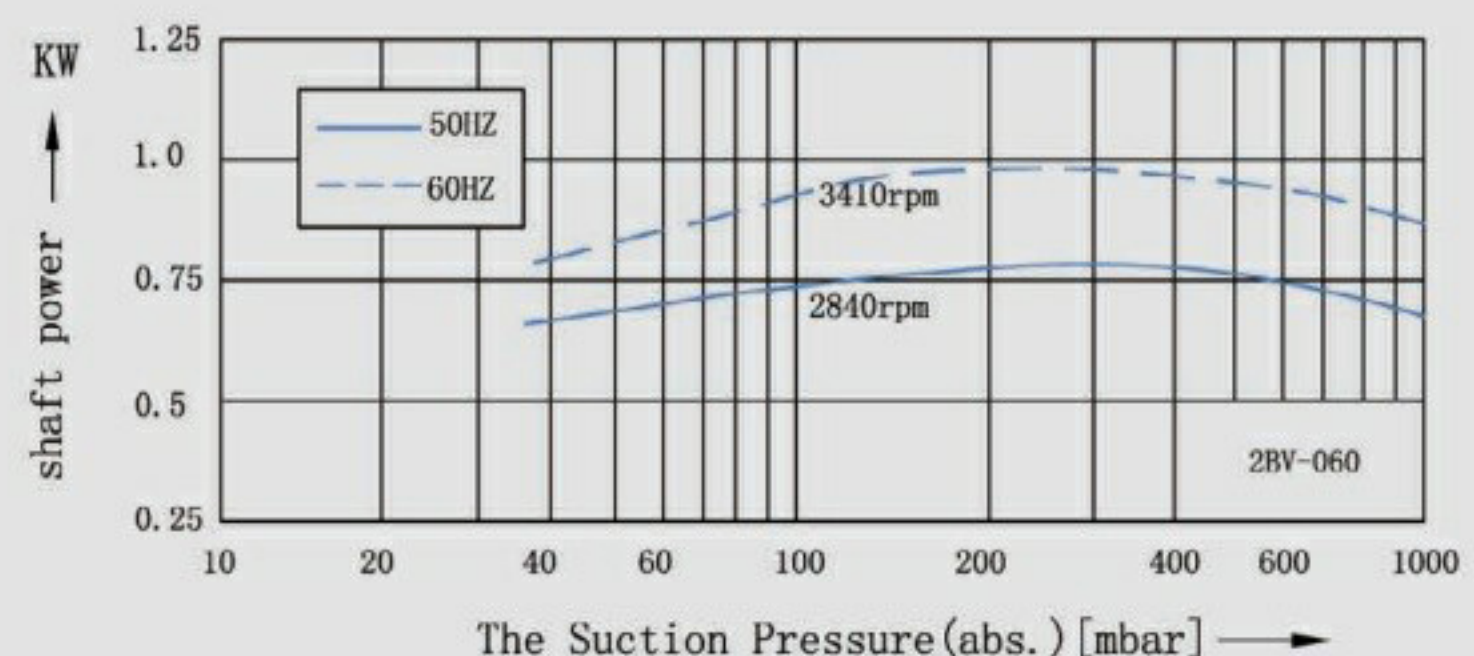
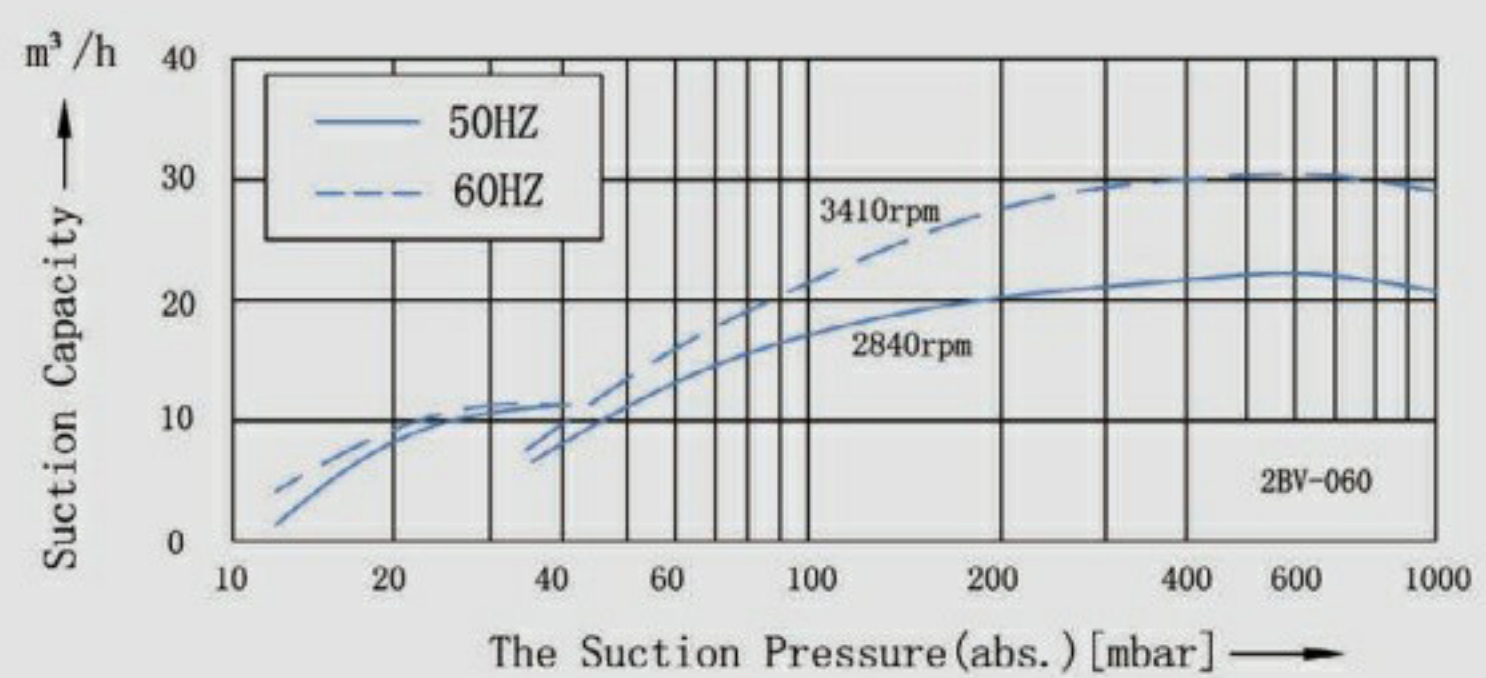

2BE1-102-253系列外形尺寸图 / 2BE1-102-253 Dimension Drawing

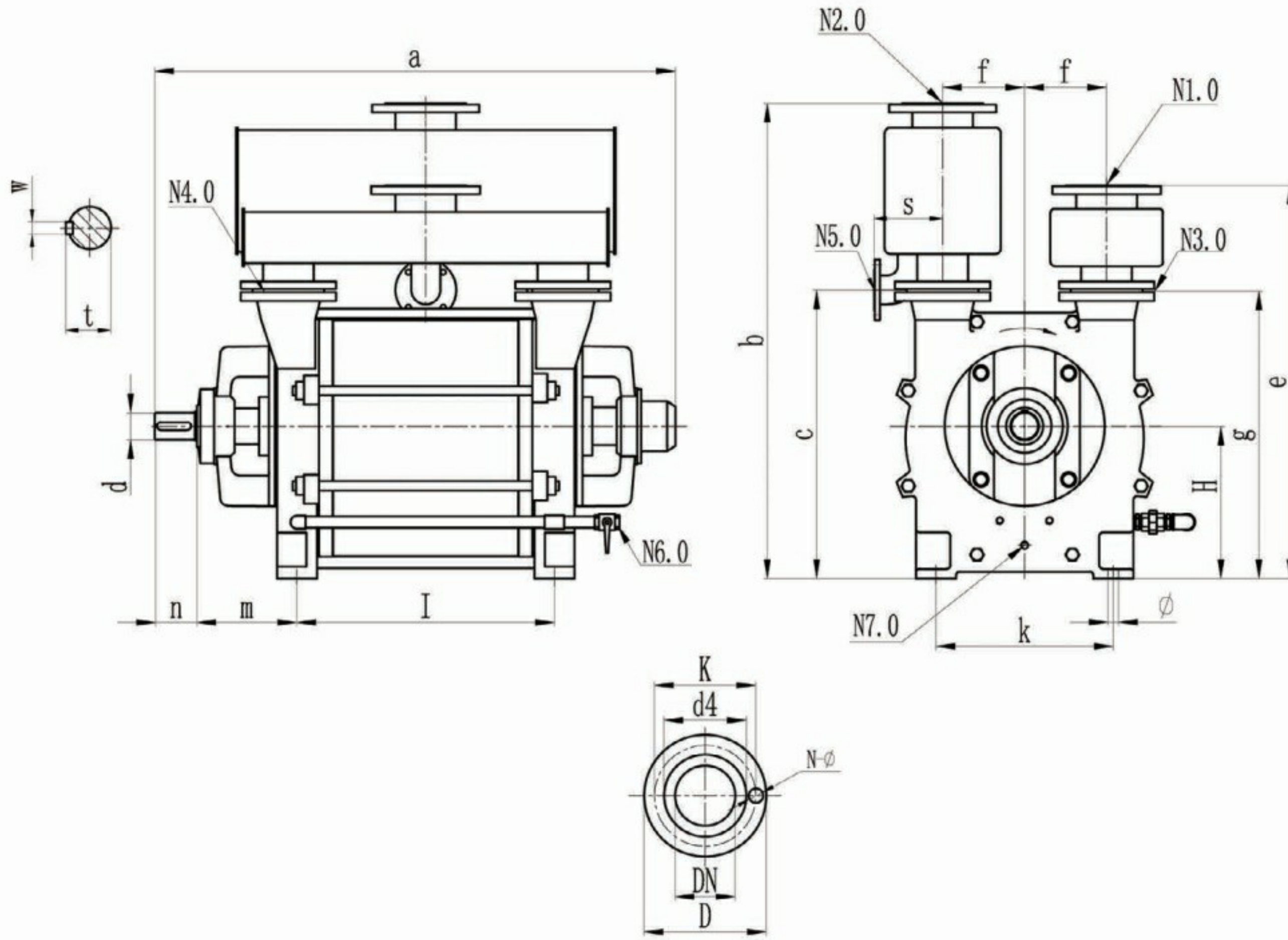

2BE1-303-405系列外形尺寸图 / 2BE1-303-405 Dimension Drawing

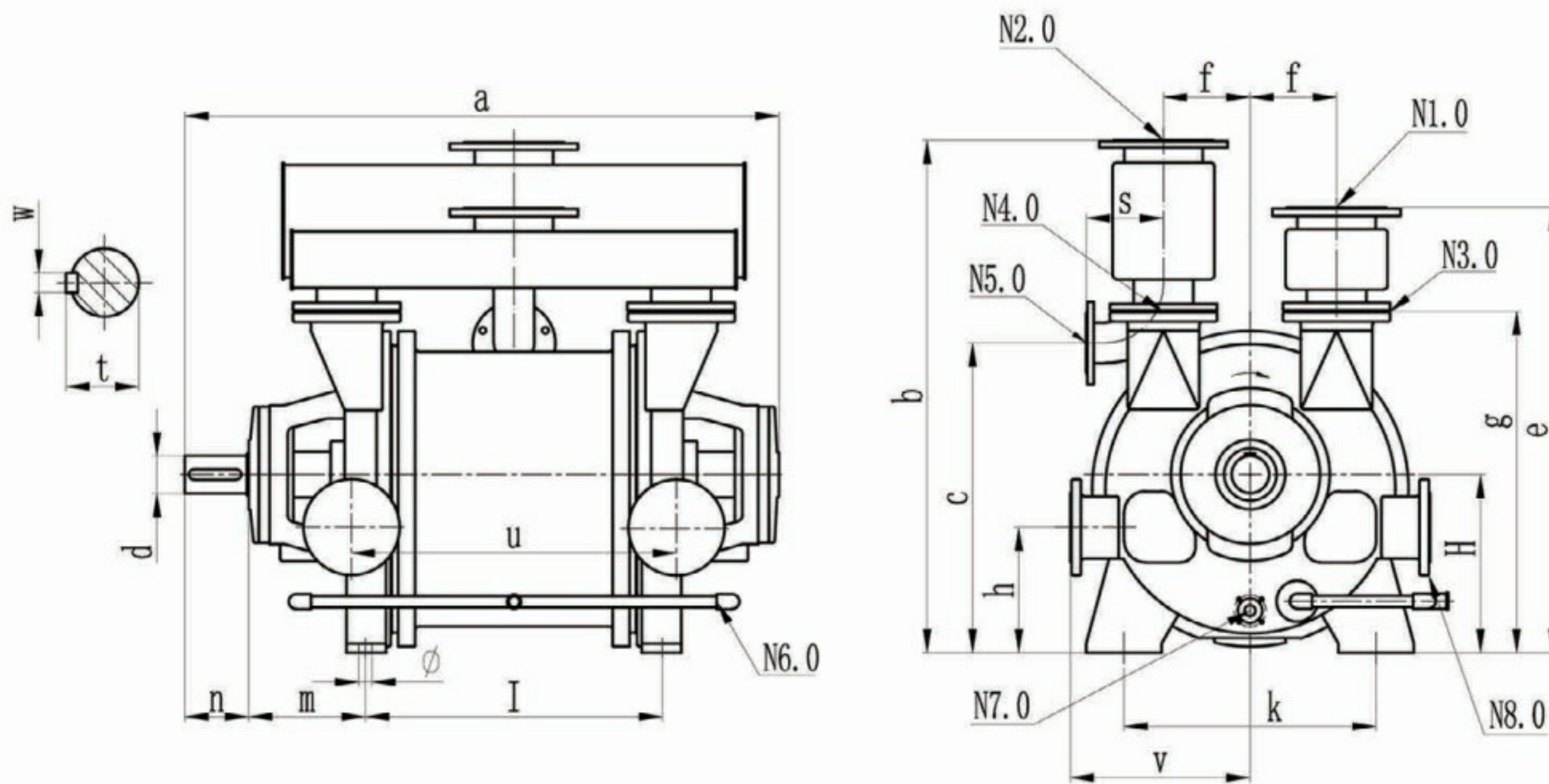

2BE1系列外形尺寸表 / 2BE1 Dimension

(unit:mm)

型号	a	b	c	e	f	g	H	l	M	n	s	k	ø	d	N	t
2BE1-102-0	746	648	318	498	105	355	180	262	194	58	110	220	15	35	10	38
2BE1-103-0	800	648	318	498	105	355	180	316	194	58	110	220	15	35	10	38
2BE1-152-0	820	748	376	603	125	425	225	300	207	70	140	260	19	35	10	38
2BE1-153-0	900	748	376	603	125	425	225	380	207	70	140	260	19	35	10	38
2BE1-202-0	961	980	590	840	155	590	315	395	222	82	150	340	24	50	14	53.5
2BE1-203-0	1090	980	590	840	155	590	315	515	222	82	150	340	24	50	14	53.5
2BE1-252-0	1231	1248	758	1033	215	755	400	526	267	105	180	465	28	70	20	74.5
2BE1-253-0	1381	1148	758	1033	215	755	400	676	267	105	180	465	28	70	20	74.5
2BE1-303-0	1580	1365	825	1186	230	910	475	790	315	165	205	670	35	100	28	106
2BE1-305-0	1700	1365	825	1186	230	910	475	910	315	165	205	670	35	100	28	106
2BE1-353-0	1752	1573	933	1373	285	1050	560	910	340	165	245	800	35	120	32	127
2BE1-355-1	1892	1573	933	1373	285	1050	560	1050	340	165	245	800	35	120	32	127
2BE1-403-0	2020	1865	1120	1625	335	1265	670	1110	355	200	285	950	42	140	36	148
2BE1-405-1	2170	1865	1120	1625	335	1265	670	1260	355	200	285	950	42	140	36	148

注：2BE1-303-405型泵根据需要亦可作垂直吸气水平排气布置（不带顶部的气水分离器），或水平吸排气（不带顶部三通和气水分离器）此时有关安装见下表：

NOTE:2BE1-303-405 pumps can be arranged as vertically suction and horizontally discharging(without built-in separator),or arranged as horizontally suction and vertically discharging(without pipe and separator).In this case ,please refer to the right table about the installation.

型号	h	u	v
2BE1-303	335	864	505
2BE1-305	335	984	505
2BE1-353	395	1000	555
2BE1-355	395	1140	555
2BE1-403	475	1210	655
2BE1-405	475	1360	655

型号 MODEL	N1.0=N2.0(进排气口法兰)					N3.0=N4.0=N5.0(泵法兰)					N5.0(排水口法兰)					N6.0 (工作液进)	N7.0 (工作液排)
	DN	D	K	d4	N-ø	DN	D	K	d4	N-ø	DN	D	K	d4	N-ø		
2BE1-102-0	65	158	145	118	4-18	50	165	125	95	4-18	40	150	110	84	4-18	G1/2"	G1/2"
2BE1-103-0	65	185	145	118	4-18	50	165	125	95	4-18	40	150	110	84	4-18	G1/2"	G1/2"
2BE1-152-0	100	220	180	156	8-18	65	185	145	125	4-18	50	165	125	99	4-18	G1/2"	G1/2"
2BE1-153-0	100	220	180	156	8-18	65	185	145	125	4-18	50	165	125	99	4-18	G1/2"	G1/2"
2BE1-202-0	125	250	210	184	8-18	100	220	180	158	4-14	68	160	130	108	4-14	G3/4"	G3/4"
2BE1-203-0	125	250	210	184	8-18	100	220	180	158	4-14	68	160	130	108	4-14	G3/4"	G3/4"
2BE1-252-0	150	285	240	212	8-22	125	250	210	188	4-14	68	160	130	108	4-14	G1"	G1"
2BE1-253-0	150	285	240	212	8-22	125	250	210	188	4-14	68	160	130	108	4-14	G1"	G1"
2BE1-303-0	200	340	295	265	8-22	160	285	240	212	8-18	100	220	180	158	8-18	G1"	G1"
2BE1-305-0	200	340	295	265	8-22	160	285	240	212	8-18	100	220	180	158	8-18	G1"	G1"
2BE1-353-0	250	395	350	320	12-22	210	350	295	268	8-22	125	250	210	184	8-22	G1 1/2"	G1 1/2"
2BE1-355-1	250	395	350	320	12-22	210	350	295	268	8-22	125	250	210	184	8-22	G1 1/2"	G1 1/2"
2BE1-403-0	300	445	400	370	12-22	260	405	362	320	8-22	150	285	240	211	8-22	G1 1/2"	G1 1/2"
2BE1-405-1	300	445	400	370	12-22	260	405	362	320	8-22	150	285	240	211	8-22	G1 1/2"	G1 1/2"

## 2BE3 系列外形尺寸图 / 2BE3 Dimension Drawing

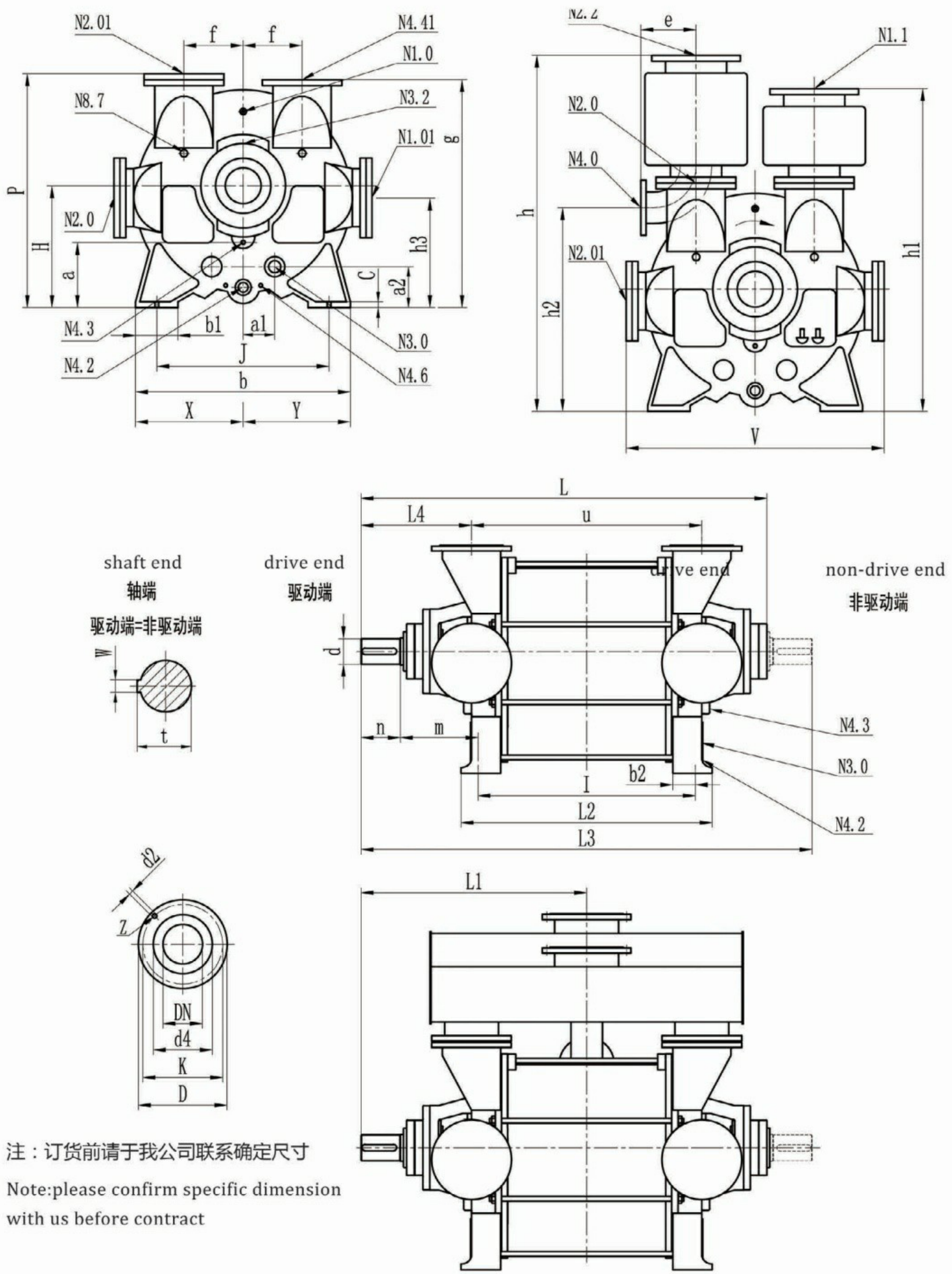

注：订货前请于我公司联系确定尺寸  
 Note: please confirm specific dimension with us before contract

2BE3 系列外形尺寸表 / 2BE3 Dimension Drawing

unit: (mm)

型号 Model	N1.0/1.01(入口法兰/Inlet flange)						N1.1(连通管法兰/Connecting pipe flange)						N2.0/2.01(出口法兰/Outlet flange)					
	DN	d2	d4	D	K	Z	DN	d2	d4	D	K	Z	DN	d2	d4	D	K	Z
2BE3-40/42	260	22	320	405	362	12	300	22	363	440	395	12	260	22	320	405	362	12
2BE3-50/52	300	22	363	440	395	12	350	22	420	505	460	16	300	22	363	440	395	12
2BE3-60/62	350	22	420	505	460	16	400	26	480	595	515	16	350	22	420	505	460	16
2BE3-67	350	22	420	505	460	16	500	26	585	670	620	20	350	22	420	530	460	16
2BE3-72	400	26	470	595	515	16	500	26	585	670	620	20	400	26	470	595	515	16
2BEN-80	500	26	585	670	620	20	600	30	682	780	725	20	500	26	585	670	620	20
2BEN-90	500	26	585	670	620	20	600	30	682	780	725	20	500	26	585	670	620	20
2BEN-100	600	30	682	780	725	20	700	30	800	895	840	24	600	30	682	780	725	20

型号 Model	N2.2(分离器出口法兰/Separator discharge flange)						N3.0(工作液接口/Operating liquid connection)						N4.0(分离器接口/Separator connection)					
	DN	d2	d4	D	K	Z	DN	d2	d4	D	K	Z	DN	d2	d4	D	K	Z
2BE3-40/42	300	22	363	440	395	12	50	M12	80	-	102	4	150	22	210	280	240	8
2BE3-50/52	350	22	420	505	460	16	60	M12	-	120	90	4	200	22	266	340	295	8
2BE3-60/62	400	26	480	595	515	16	80	M16	128	-	150	4	200	22	266	340	295	8
2BE3-67	500	26	585	670	620	20	80	M16	128	-	150	4	200	22	266	340	295	8
2BE3-72	500	26	585	670	620	20	80	M16	128	-	150	4	200	22	320	395	350	12
2BEN-80	600	30	682	780	725	20	80	M16	128	-	150	4	250	22	320	395	350	12
2BEN-90	600	30	682	780	725	20	80	M16	128	-	150	4	250	22	320	395	350	12
2BEN-100	700	30	800	895	840	24	100	M16	148	-	170	4	300	22	370	445	400	12

型号 Model	N4.2(冲洗及排液口/Flush and drainage port)						N3.2	N4.3	N4.41	N4.6	N8.7
	DN	d2	d4	D	K	Z					
2BE3-40/42	50	M12	80	-	102	4	G1/4"	G3/4"	G1/2"	G1/2"	G1/2"
2BE3-50/52	60	M12	-	120	90	4	G1/2"	G3/4"	G1/2"	G1/2"	G1/2"
2BE3-60/62	80	M16	128	-	150	4	G1/2"	G3/4"	G1/2"	G1/2"	G1/2"
2BE3-67	80	M16	128	-	150	4	G1/2"	G3/4"	G1/2"	G1/2"	G1/2"
2BE3-72	80	M16	128	-	150	4	G1/2"	G3/4"	G1/2"	G1/2"	G1/2"
2BEN-80	80	M16	128	-	150	4	G1/2"	G3/4"	G1/2"	G1/2"	G1/2"
2BEN-90	100	M16	128	-	150	4	G1/2"	G3/4"	G1/2"	G1/2"	G1/2"
2BEN-100	100	M16	148	-	170	4	G1/2"	G3/4"	G3/4"	G3/4"	G1/2"

型号 Model	a	a1	a2	b	b1	b2	c	d	e	f	g	H	h	h1	h2	h3	I	J
2BE3-40	332	160	209	1090	215	200	30	Φ130	280	300	1160	620	1810	1640	1035	560	1103	875
2BE3-42	332	160	209	1090	215	200	30	Φ130	280	300	1160	620	1810	1640	1035	560	1391	875
2BE3-50	451	175	227	1370	250	250	35	Φ160	367	385	1450	775	2238	1938	1256	698	1479	1120
2BE3-52	451	175	227	1370	250	250	35	Φ160	367	385	1450	775	2238	1938	1256	698	1729	1120
2BE3-60	560	200	249	1620	300	300	40	Φ180	367	435	1720	900	2613	2223	1563	810	1747	1320
2BE3-62	560	200	249	1620	300	300	40	Φ180	367	435	1720	900	2613	2223	1563	810	2042	1320
2BE3-67	576	200	260	1740	320	300	45	Φ200	367	460	1885	975	2803	2433	1663	876	2200	1400
2BE3-72	655	200	273	1900	340	340	45	Φ200	449	460	1985	1060	3023	2573	1753	952	2410	1600
2BEN-80	744	230	303	2140	380	380	50	Φ230	450	560	2260	1204	3200	3200	2160	1082	2960	1800
2BEN-90	872	250	376	2340	390	420	50	Φ230	460	600	2570	1370	3500	3500	2460	1232	3120	1950
2BEN-100	985	290	380	2760	480	480	55	Φ260	620	710	2830	1520	4330	3730	2490	1366	3370	2280

型号 Model	L	L1	L2	L3	L4	m	n	p	Φ	t	u	v	w	x	y
2BE3-40	2090	1145	1274	2290	561	394	200	1195	42	137	1169	1302	32	625	660
2BE3-42	2328	1261	1562	2528	561	394	200	1195	42	137	1458	1302	32	625	660
2BE3-50	2588	1456	1713	2888	672	412	300	1481	42	173	1568	1562	40	750	790
2BE3-52	2838	1582	1963	3138	672	412	300	1481	42	173	1818	1562	40	750	790
2BE3-60	2834	1568	2047	3134	646	395	300	1753	48	190	1843	1818	45	879	909
2BE3-62	3129	1716	2342	3429	646	395	300	1753	48	190	2138	1818	45	879	909
2BE3-67	3382	1874	2476	3732	734	436	350	1878	48	210	2280	1916	45	926	958
2BE3-72	3579	1973	2730	3929	733	418	350	2017	48	210	2500	2096	45	1016	1048
2BEN-80	4066	2212	3160	4040	733	432	350	2290	48	241	2960	2370	50	1165	1185
2BEN-90	4370	2385	3560	4402	816	476	350	2610	50	243	3260	2680	50	1300	1340
2BEN-100	4795	2613	3810	5226	853	528	400	2880	60	272	3520	3040	56	1470	1520

## ● 2BV 系列水环式真空泵及压缩机

2BV Series Liquid Ring Vacuum Pumps and Compressors

● 2BV 系列水环真空泵适用于抽除气体和水蒸汽，吸气压力可以达到 33mbar 绝压（97% 真空度）当水环真空泵在吸气压力接近极限真空（工作液的饱和蒸汽压）下长期工作时，应连接气蚀保护管，以对泵进行保护。作为压缩机用时，其压力最大至 0.26Mpa（绝压）。2BV 系列水环真空泵作为新一代节能型产品，以其出色的性能及众多优点将全面取代同性能的 SK、2SK 系列水环真空泵及 W、WY、WL 系列往复真空泵。

2BV6 系列水环式真空泵及压缩机主要用于抽除爆炸性气体，及在各类易燃易爆环境中工作，其性能参数与 2BV2、2BV5 系列相同。

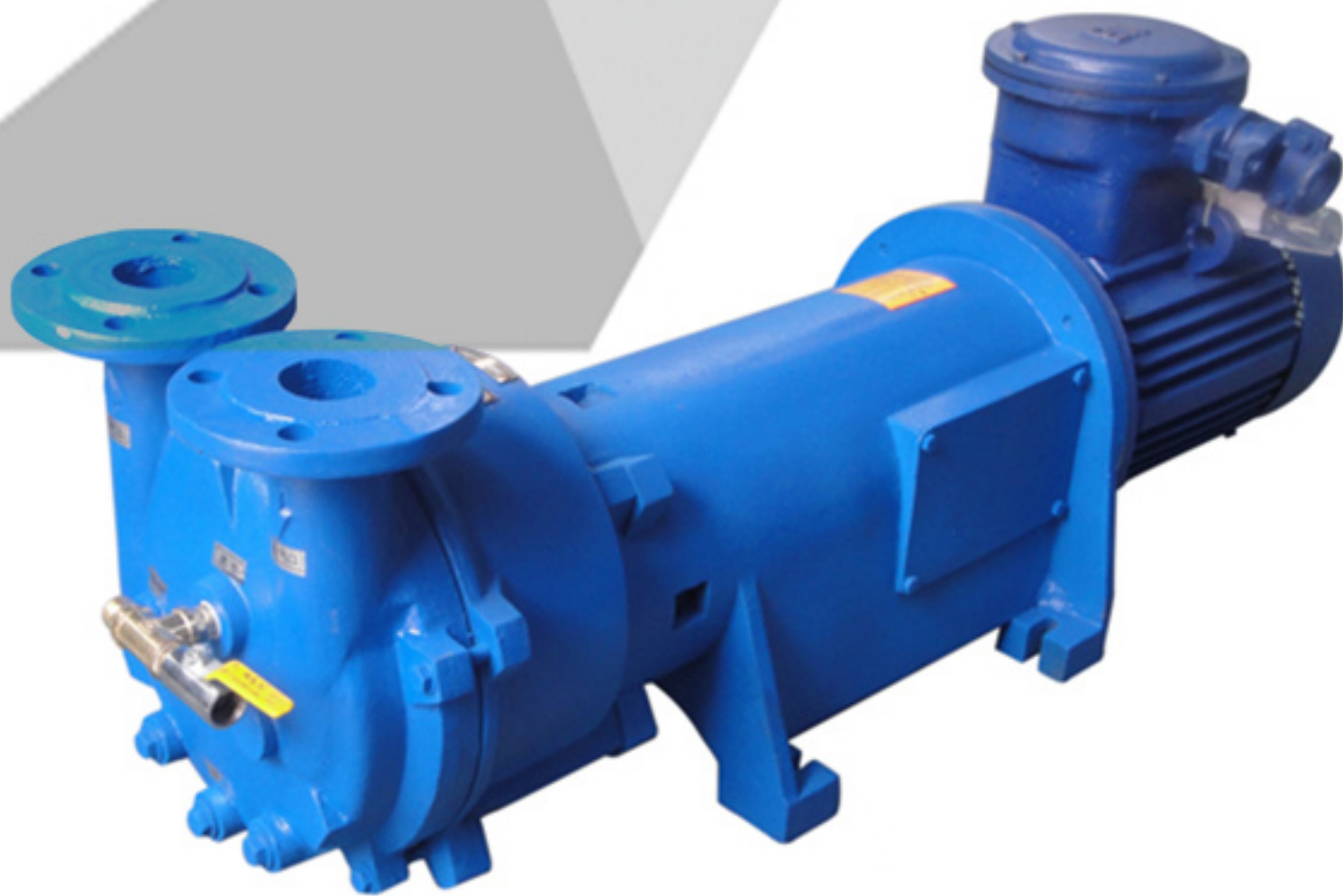

2BV series water ring vacuum pump is suitable for removing gas and water vapor, and the suction pressure can reach 33mbar absolute pressure (97% vacuum degree). When the cavitation protection pipe should be connected to protect the pump. When used as a compressor, its maximum pressure is 0.26Mpa (absolute pressure). As a new generation of energy-saving products, 2BV series water ring vacuum pump will completely replace the SK, 2SK series water ring vacuum pumps and W, WY, WL series reciprocating vacuum pumps of the same performance with its excellent performance and many advantages.

2BV6 series water ring vacuum pumps and compressors are mainly used for pumping out explosive gas and working in various flammable and explosive environments. Their performance parameters are the same as 2BV2 and 2BV5 series.

2BV 技术性能表

2BV Technical Parameters

产品型号 model	最大气量 max. capacity m <sup>3</sup> /h	进排气口 inlet &outlet	供水口 feed water inlet	电机功率 motor power kW 50HZ	电机防 爆等级 motor explosion- proof grade	泵转速 pump speed rpm	工作液流量 operating liquid flow L/min	噪音 noise dB(A)	重量 weight kg
2BV2-060	27	G1"	G3/8"	Y90S-2-0.81	不 防 爆 non- explosion proof	2840	2.5	62	31
2BV2-061	52	G1"	G3/8"	Y90S-2-1.45		2840	2.5	65	36
2BV2-070	80	G1.5"	G3/8"	Y100L-2-2.35		2860	3	66	56
2BV2-071	110	G1.5"	G3/8"	Y112M-2-3.85		2880	4.7	72	60
2BV5-110	165	DN50	G1/2"	Y112-4-4KW		1440	7.2	63	105
2BV5-111	230	DN50	G1/2"	Y132-4-5.5KW		1440	8.8	68	126
2BV5-121	280	DN65	G3/4"	Y132-4-7.5KW		1440	11	69	149
2BV5-131	400	DN65	G3/4"	Y160-4-11KW		1460	16	73	195
2BV5-161	500	DN80	G3/4"	Y180-6-15KW		970	22	74	320
产品型号 model	最大气量 max. capacity m <sup>3</sup> /h	进排气口 inlet &outlet	供水口 feed water inlet	电机功率 motor power kW 50HZ		电机防 爆等级 motor explosion- proof grade	泵转速 pump speed rpm	工作液流量 operating liquid flow L/min	噪音 noise dB(A)
2BV6-060	27	G1"	G3/8"	YB80M-2-1.1KW	防 爆 explosion proof DIIBT4/ DIICT4	2840	2.5	62	37
2BV6-061	52	G1"	G3/8"	YB90S-2-1.5KW		2840	2.5	65	41
2BV6-070	80	G1.5"	G3/8"	YB100-2-3KW		2860	3	66	66
2BV6-071	110	G1.5"	G3/8"	YB112-2-4KW		2880	4.7	72	75
2BV6-110	165	DN50	G1/2"	YB112-4-4KW		1440	6.7	63	150
2BV6-111	230	DN50	G1/2"	YB132-4-5.5KW		1440	10	68	200
2BV6-121	280	DN65	G3/4"	YB132-4-7.5KW		1440	12	69	230
2BV6-131	400	DN65	G3/4"	YB160-4-11KW		1460	17	73	280
2BV6-161	500	DN80	G3/4"	YB180-6-15KW		970	23	74	400

2BV2--060/061/070/071 剖面结构图 / Sectional Drawing

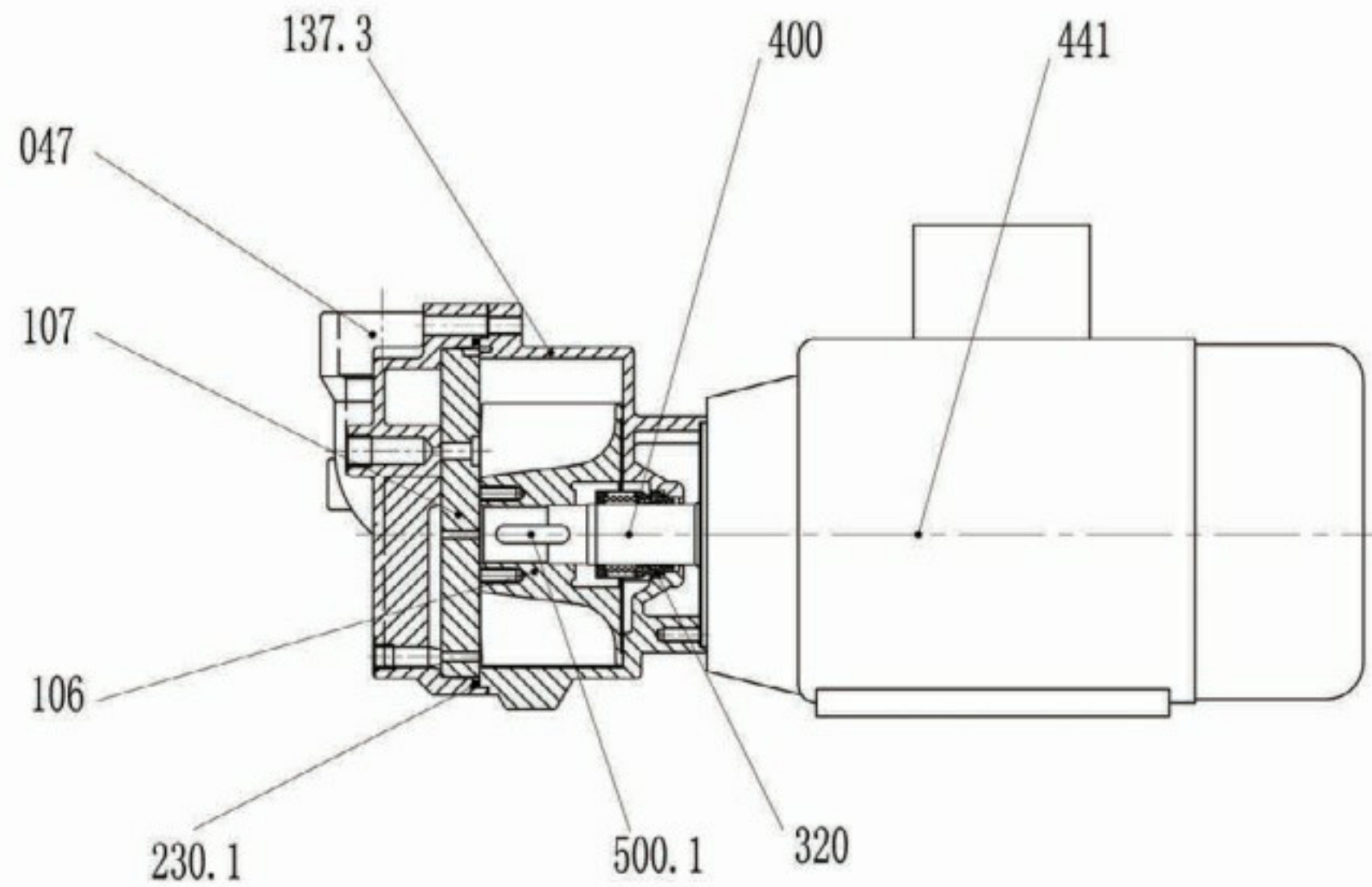

序号 No.	名称 Name	序号 No.	名称 Name
047	泵盖 pump cover	107	圆盘 port plate
106	叶轮 impeller	137.3	泵体 casing
230.1	O型圈 O-ring	320	机械密封 mechanical seal
400	电机轴 shaft	500.1	平键 flat key
441	电机 motor		

2BV6--060/061/070/071 剖面结构图 / Sectional Drawing

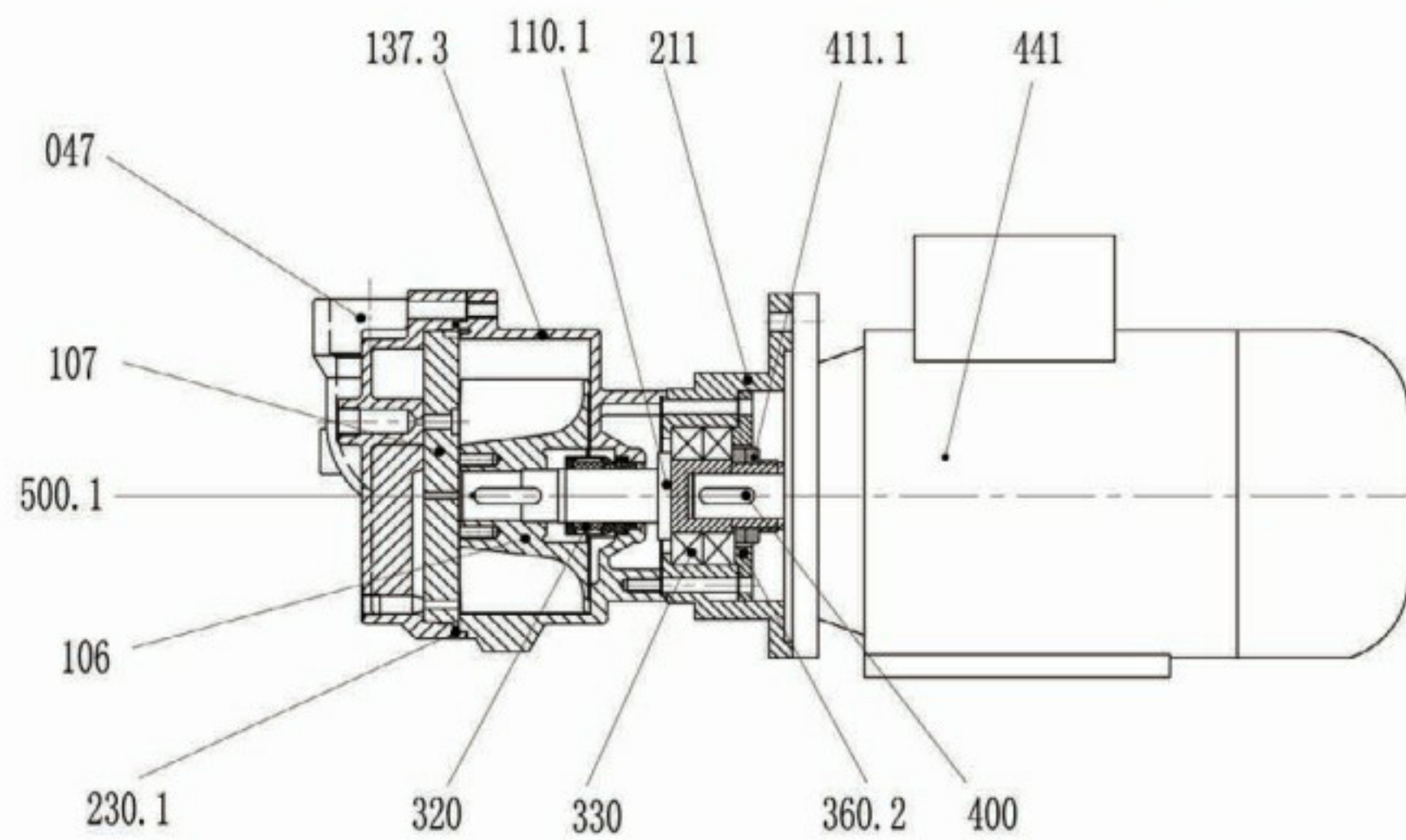

序号 No.	名称 Name	序号 No.	名称 Name
047	泵盖 pump cover	106	叶轮 impeller
107	圆盘 port plate	110.1	轴 shaft
137.3	泵体 casing	211	连接盘 bracket
230.1	O型圈 O-ring	320	机械密封 mechanical seal
330	支撑轴承 axial bearing	360.2	轴承压盖 bearing cap
400	平键 flat key	441	电机 motor
441.1	锁紧螺母 jam nut	500.1	叶轮键 flat key of rotor

## 2BV5--110/111/121/131/161系列剖面结构图 / Sectional Drawing

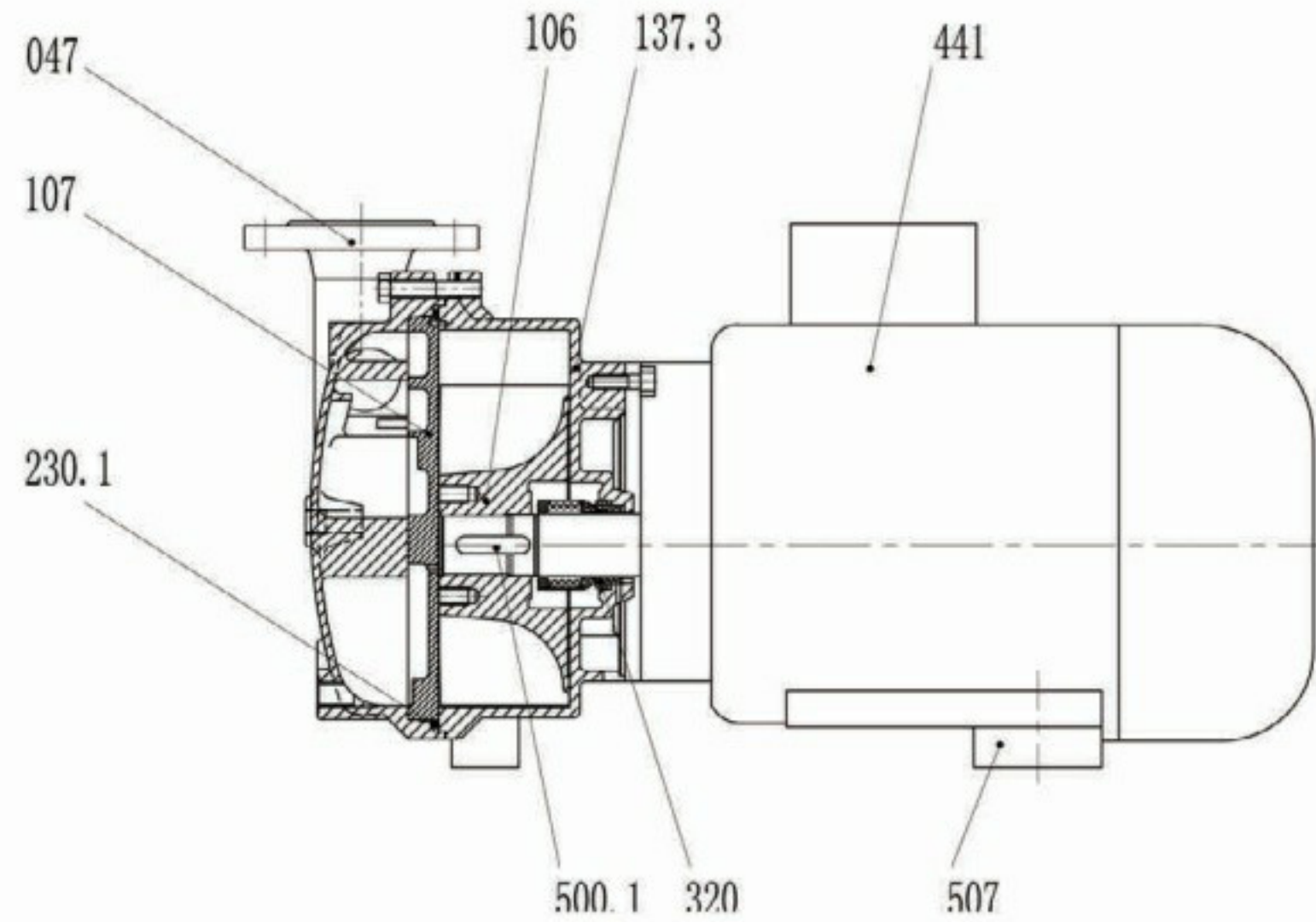

序号 No.	名称 Name	序号 No.	名称 Name
047	泵盖 pump cover	107	圆盘 port plate
106	叶轮 impeller	137.3	泵体 casing
230.1	O型圈 O-ring	500.1	平键 flat key
320	机械密封 mechanical seal	441	电机 motor
507	地脚垫板 foot gasket		

## 2BV6--110/111/121/131/161剖面结构图 / Sectional Drawing

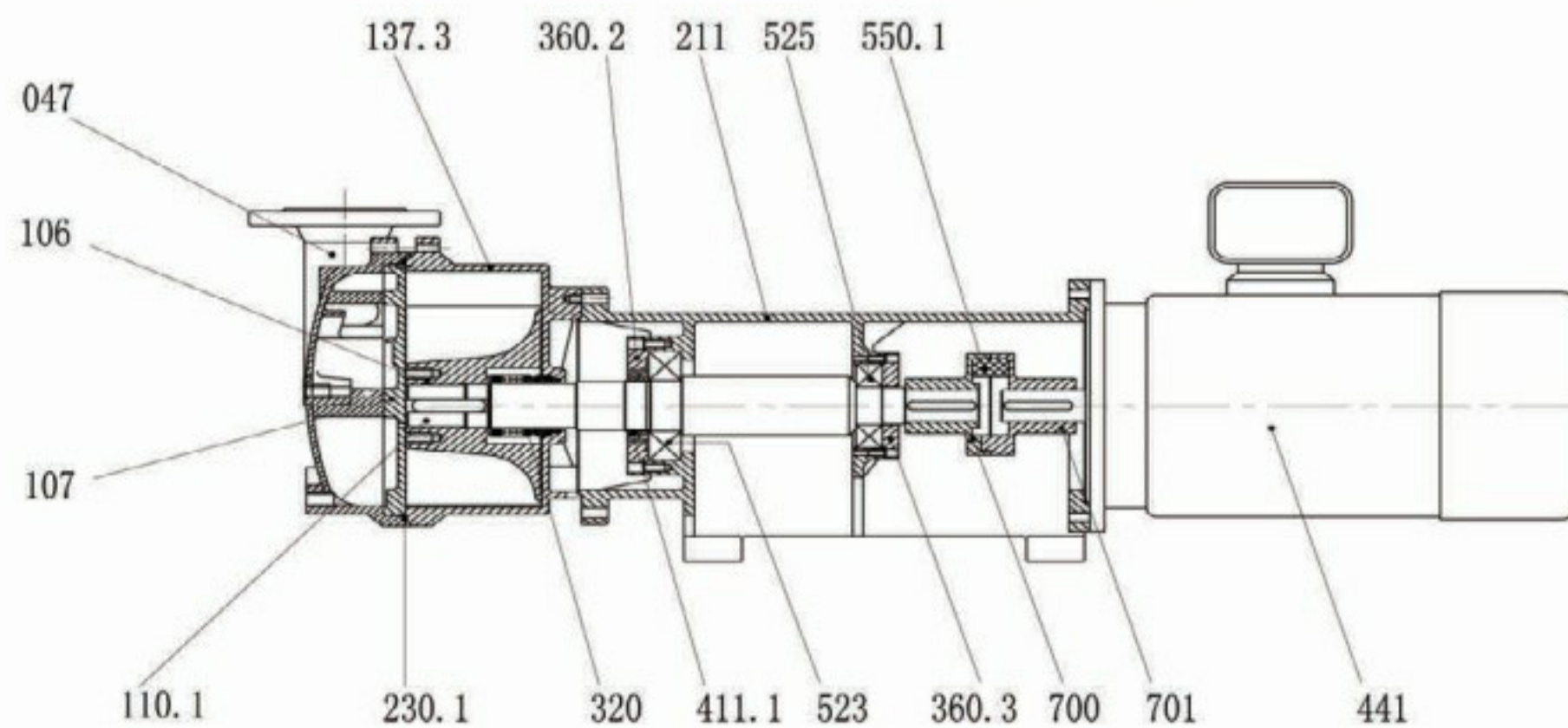

序号 No.	名称 Name	序号 No.	名称 Name
047	泵盖 pump cover	106	叶轮 impeller
107	圆盘 port plate	110.1	轴 shaft
137.3	泵体 casing	211	托架 bracket
360.2	前轴承压盖 front bearing cap	523	托架前轴承 front bearing
525	托架后轴承 back bearing	320	机械密封 mechanical seal
230.1	O型圈 O-ring	411.1	锁紧螺母 jam nut
360.3	后轴承挡盖 back bearing cover	700	泵联轴器 pump coupling
701	电联轴器 motor coupling	550.1	梅花胶圈 plum gasket
441	电机 motor		

## 2BV-061

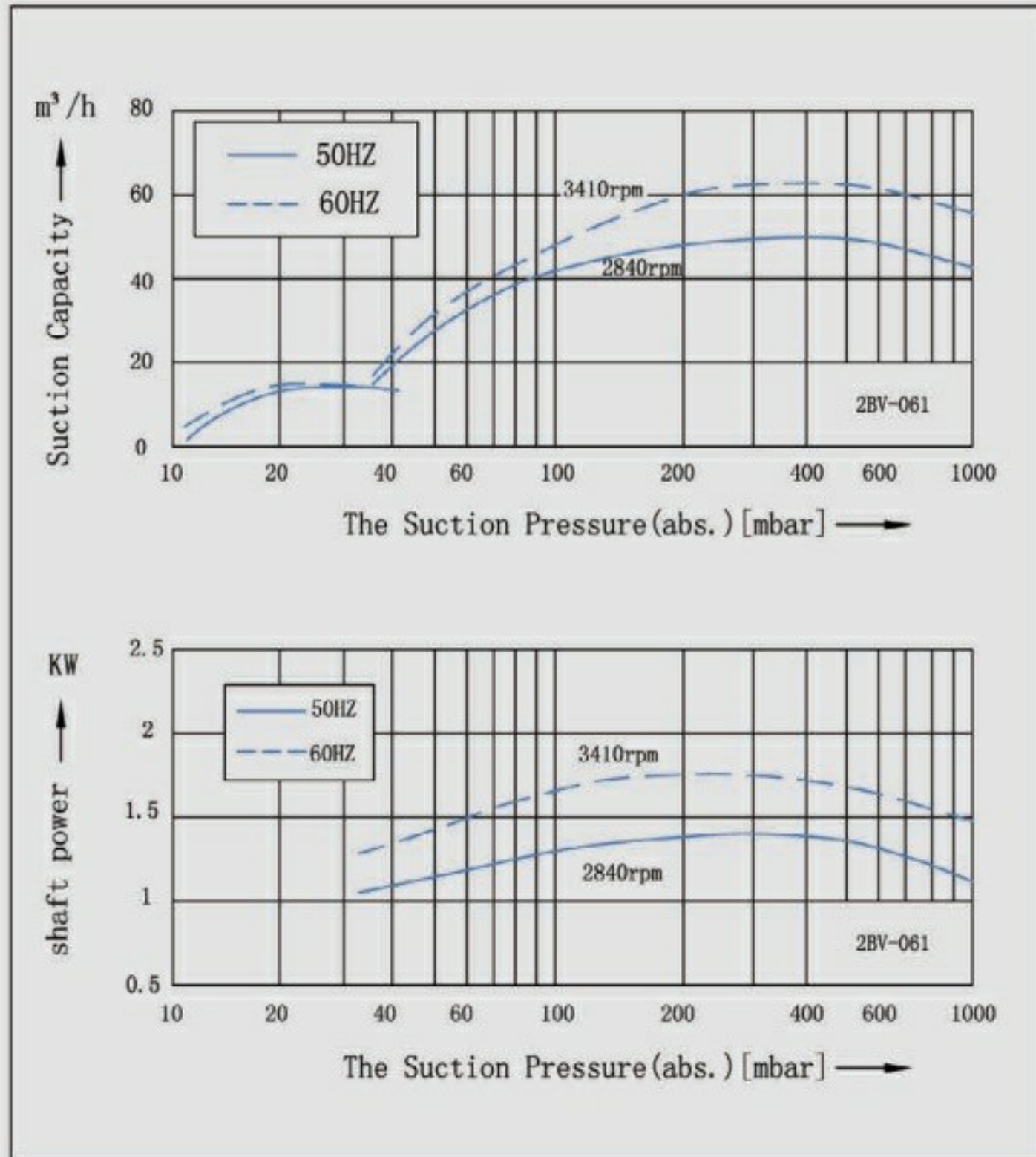

## 2BV-070

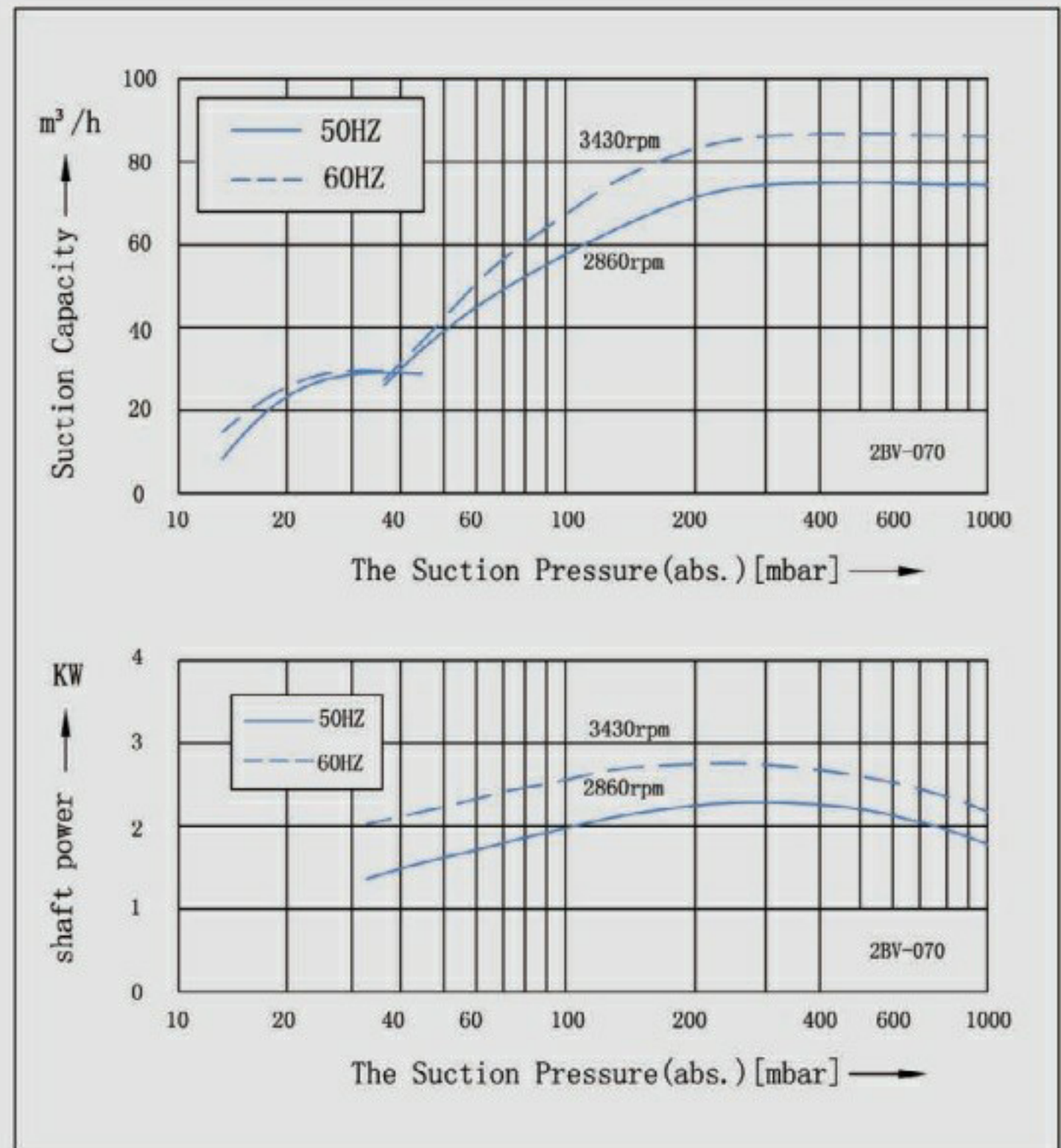

## 2BV-071

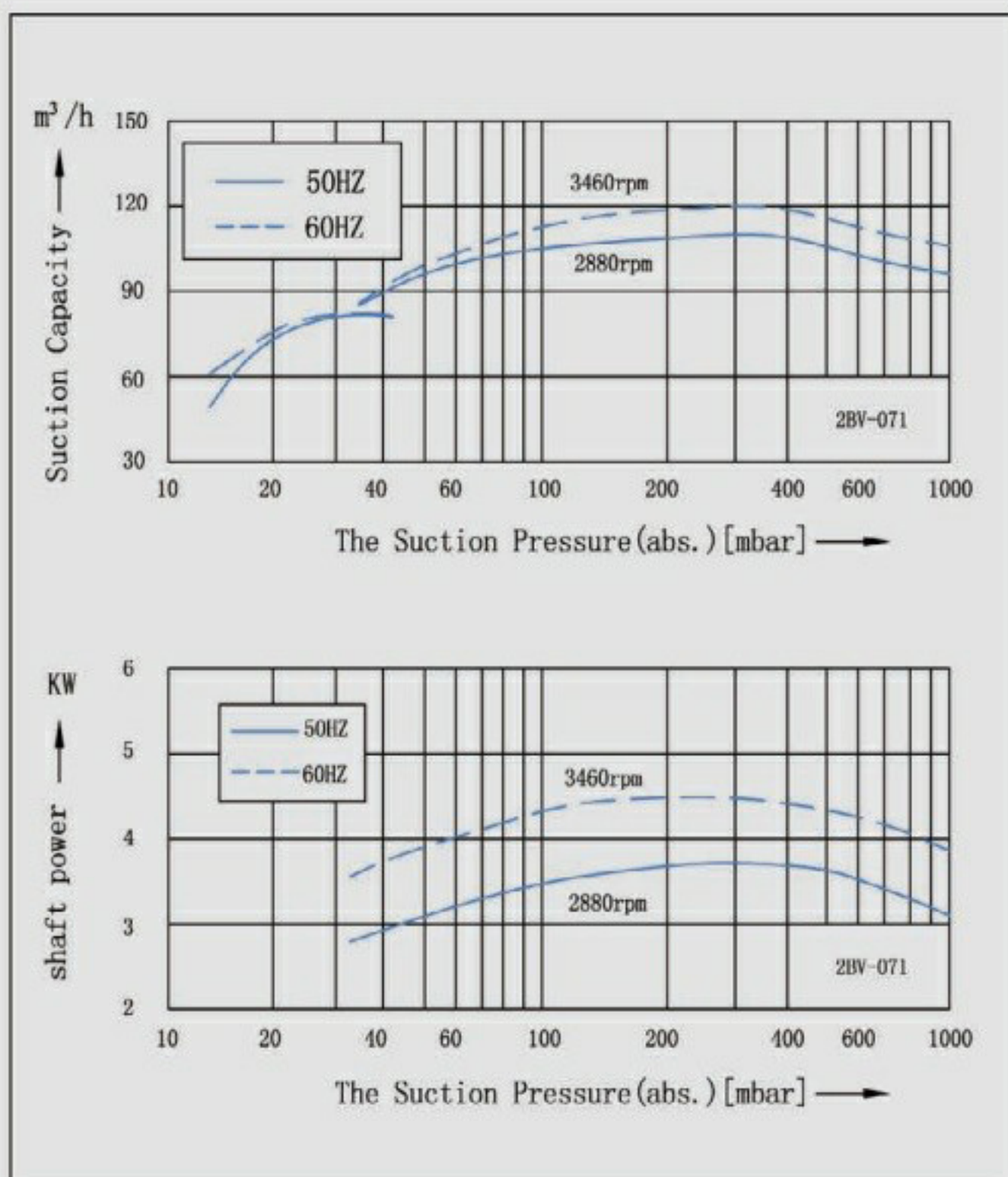

## 2BV-110

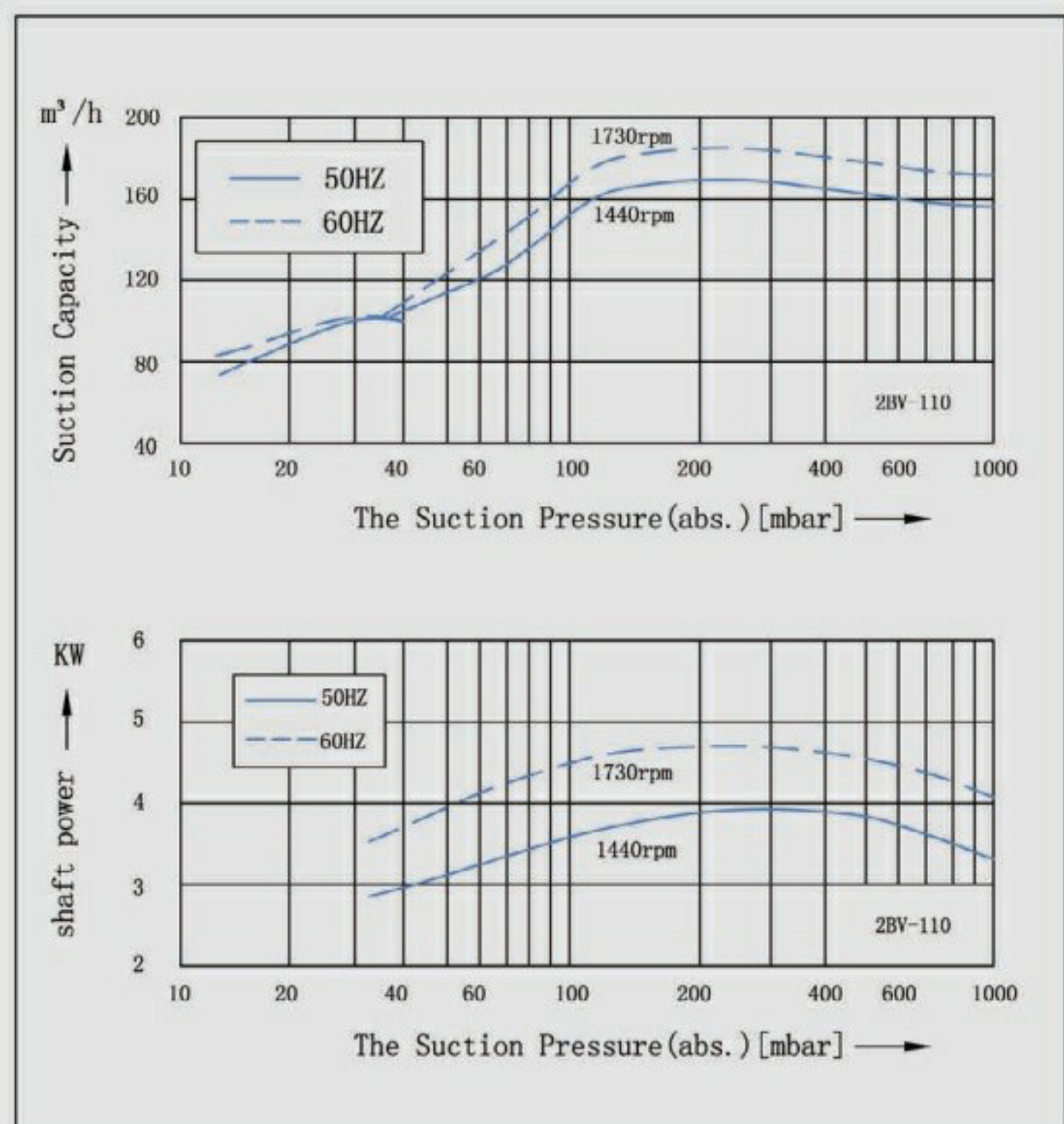

## 2BV-111

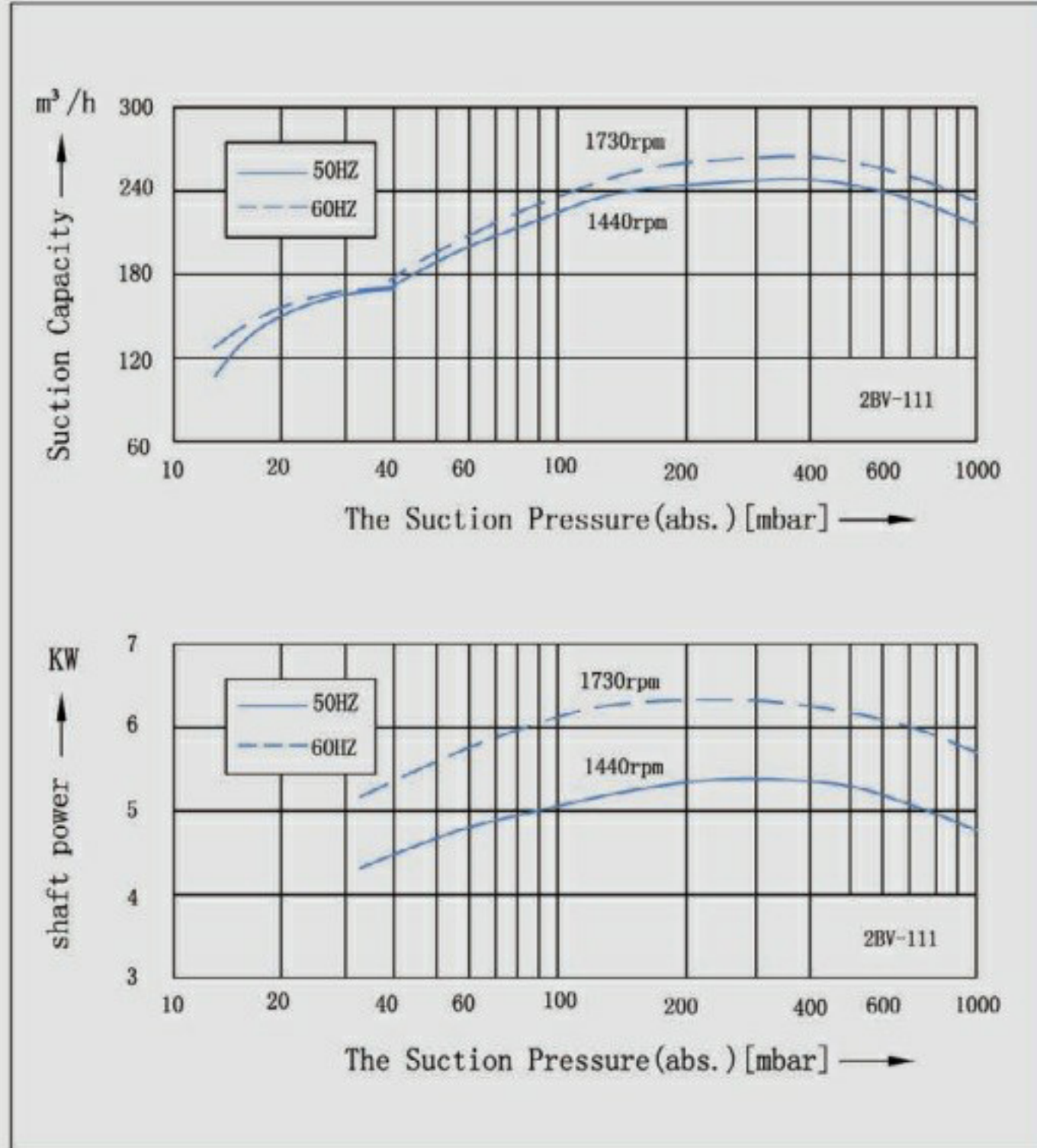

## 2BV-121

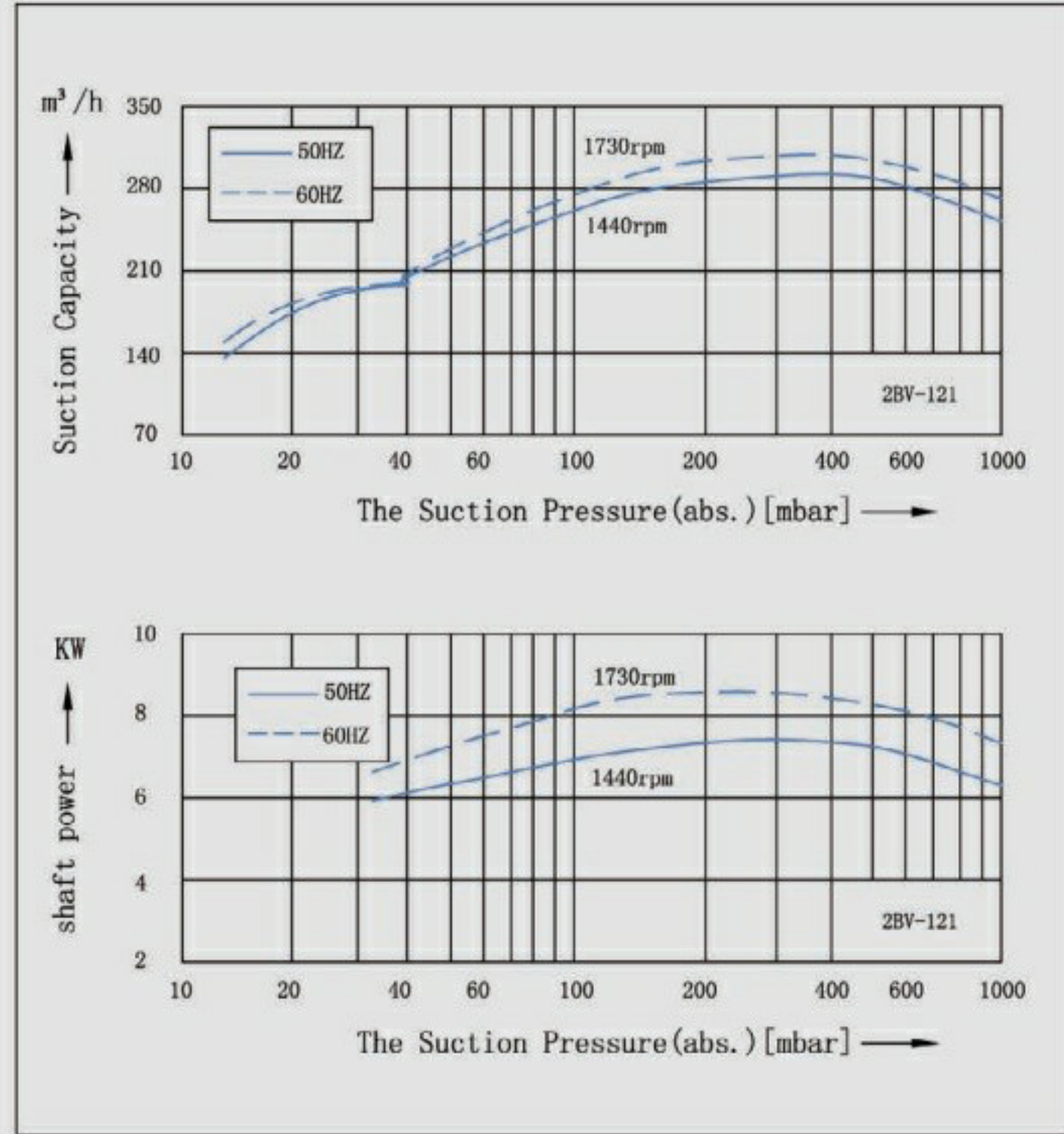

## 2BV-131

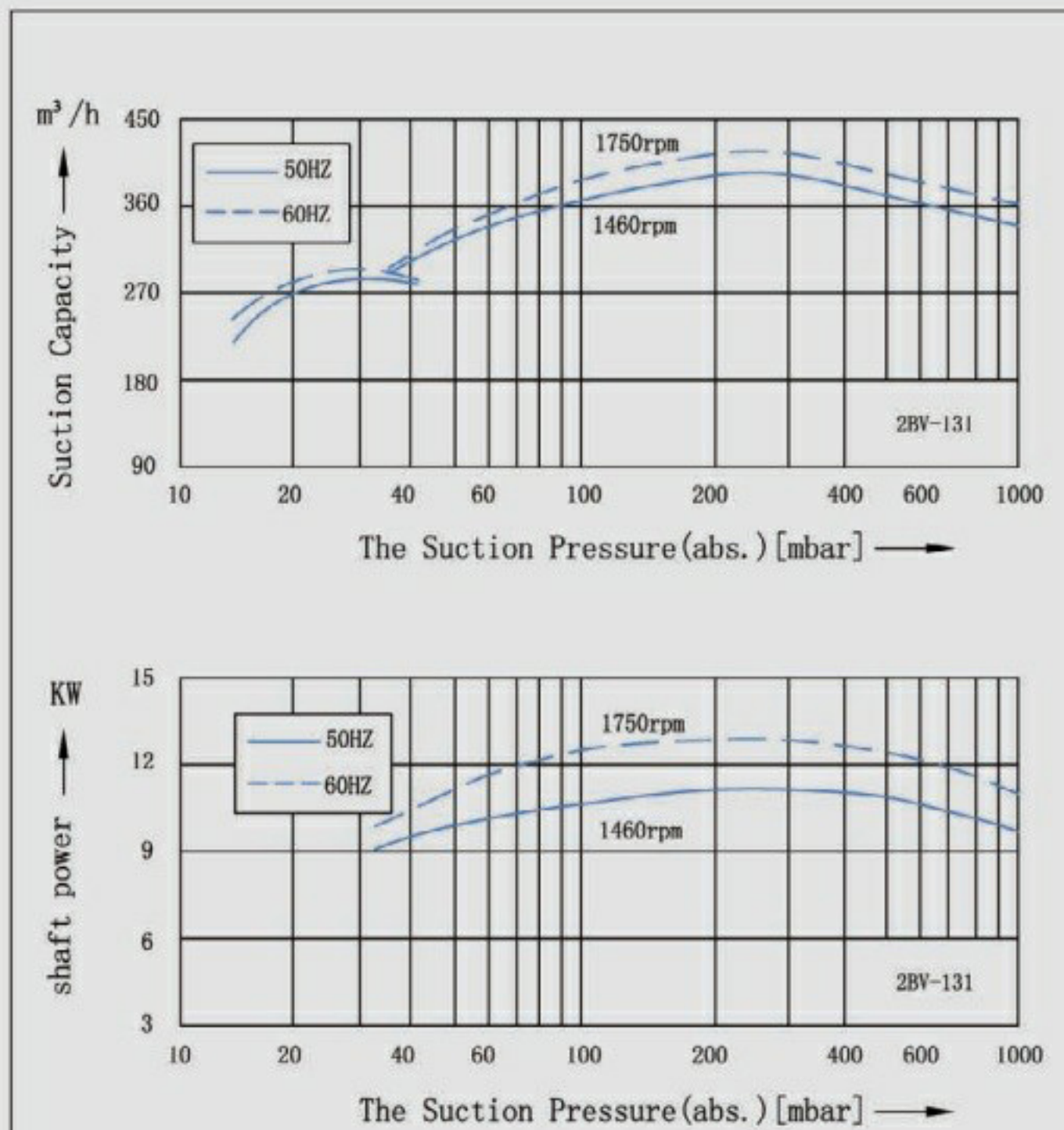

## 2BV-161

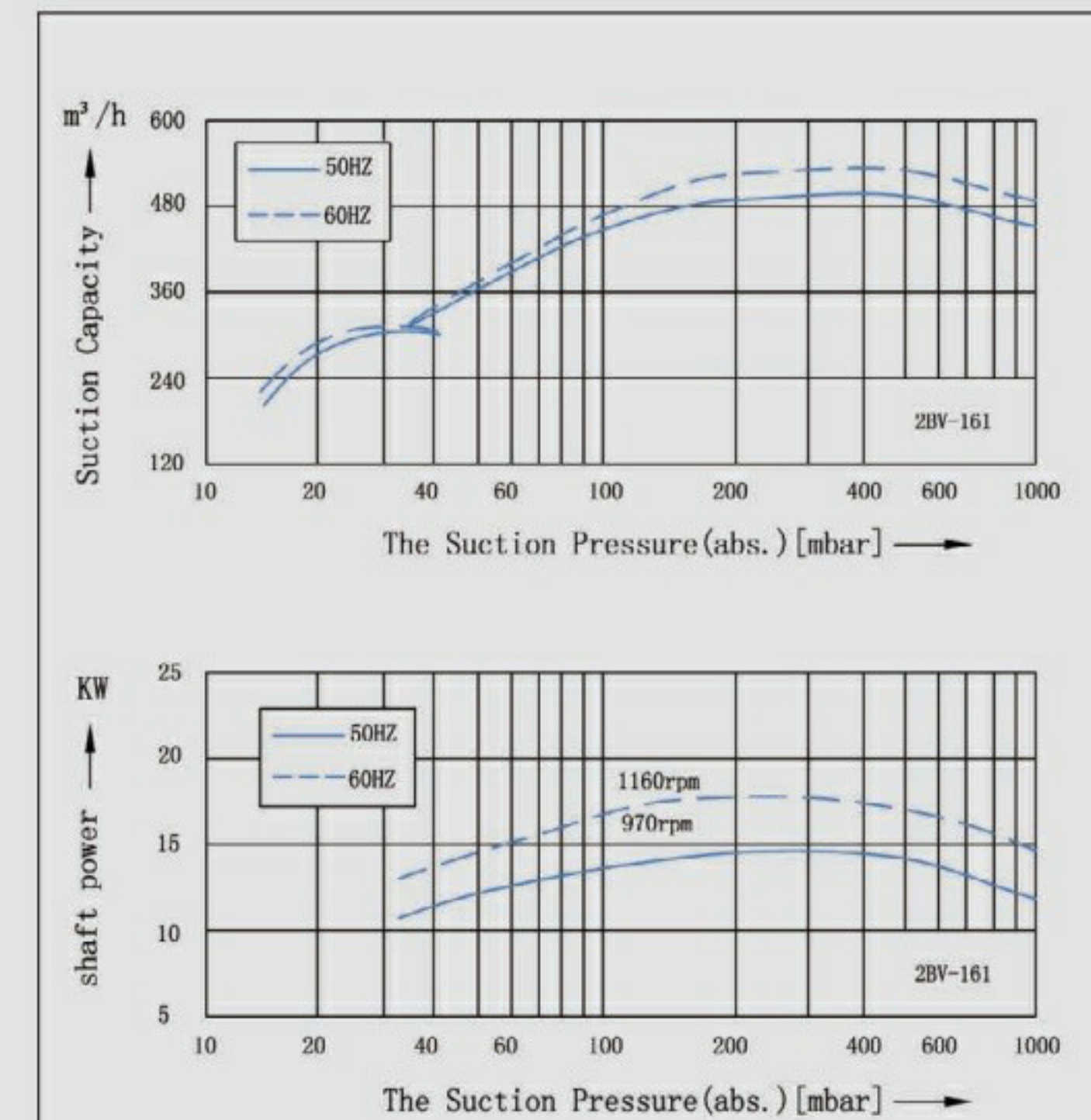

## 2BV2 系列外形尺寸图 / 2BV2 Series Dimension Drawing

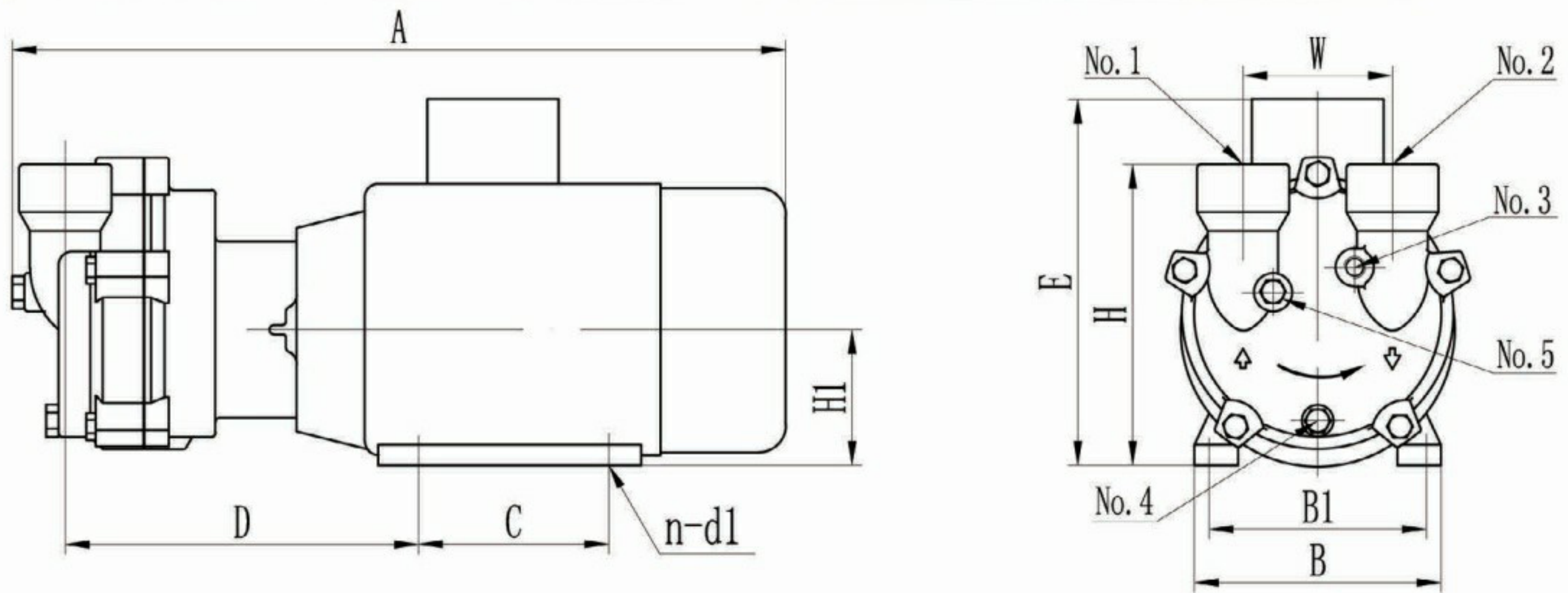

No.1 排气口 discharge port No.2 进气口 suction port No.3 供水口 water supply No.4 放水口 water outlet No. 5 气蚀保护接口 anti-cavitation connection

型号	A	B	B1	C	D	E	H	H1
2BV2-060	450	186	140	100	203	250	196	90
2BV2-061	475	186	140	100	223	250	196	90
2BV2-070	565	224	160	140	260	270	222	100
2BV2-071	590	224	160	140	260	300	222	112
型号	W	n	d1	No. 1	No. 2	No. 3	No. 4	No. 5
2BV2-060	110	4	10	G1"	G1"	G3/8"	G1/4"	G3/8"
2BV2-061	110	4	10	G1"	G1"	G3/8"	G1/4"	G3/8"
2BV2-070	110	4	12	G1 1/2"	G1 1/2"	G3/8"	G1/4"	G3/8"
2BV2-071	110	4	12	G1 1/2"	G1 1/2"	G3/8"	G1/4"	G3/8"

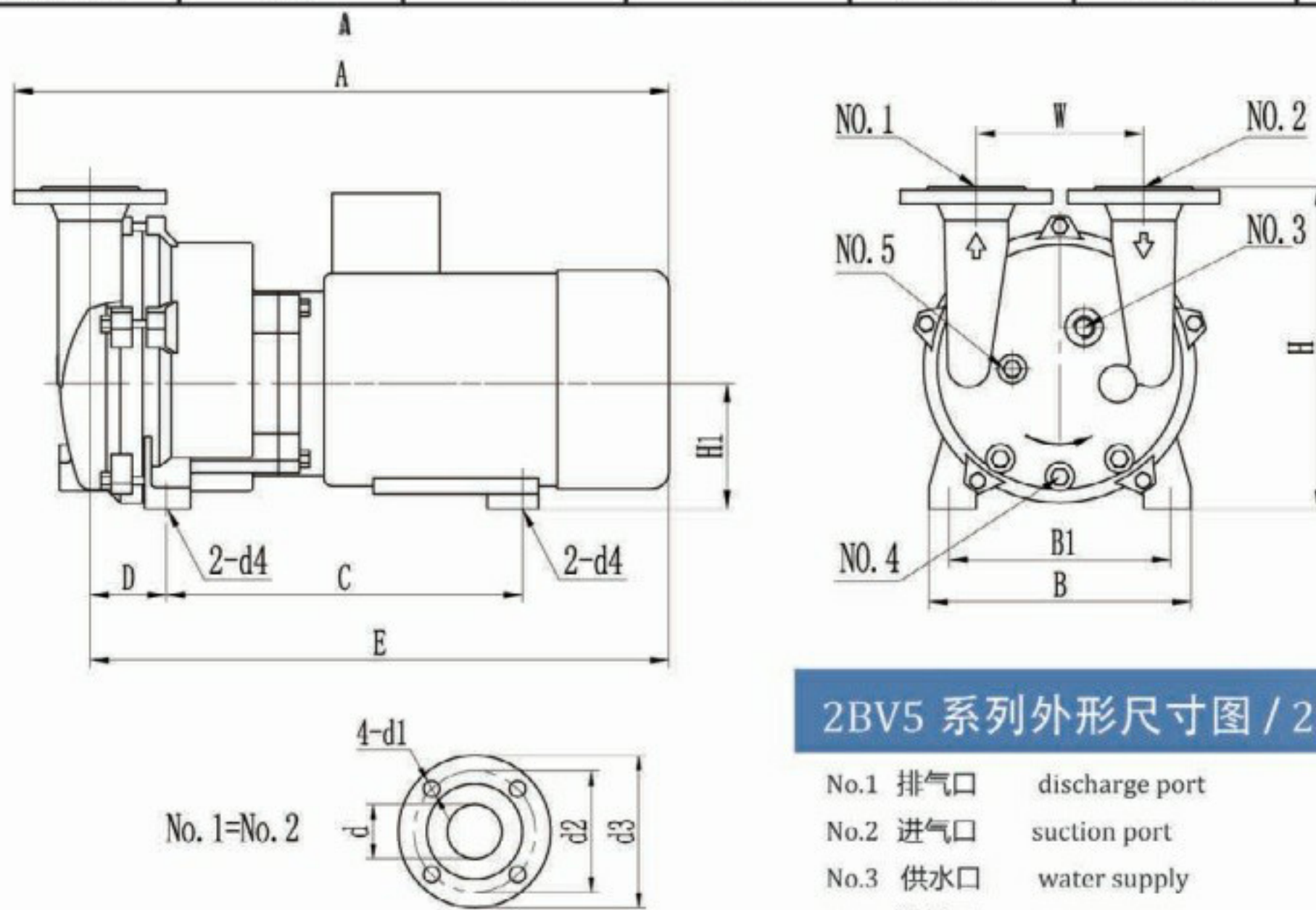

## 2BV5 系列外形尺寸图 / 2BV5 Series Dimension Drawing

No.1 排气口 discharge port  
 No.2 进气口 suction port  
 No.3 供水口 water supply  
 No.4 放水口 water outlet  
 No.5 气蚀保护接口 anti-cavitation connection

型号	A	B	B1	C	D	E	H	H1	W
2BV5-110	647	325	255	340	97	567	360	140	180
2BV5-111	669	325	265	340	106	589	371	150	180
2BV5-121	772	347	265	420	96	681	385	150	200
2BV5-131	850	377	300	475	103	759	427	175	200
2BV5-161	1060	479	370	570	137	960	521	210	250
型号	d	d1	d2	d3	d4	No. 3	No. 4	No. 5	
2BV5-110	50	19	123	160	13	G1/2"	G3/8"	G3/8"	
2BV5-111	50	19	123	160	14	G1/2"	G3/8"	G3/8"	
2BV5-121	65	19	145	182	14	G3/4"	G3/8"	G3/8"	
2BV5-131	65	19	145	182	14	G3/4"	G3/8"	G3/8"	
2BV5-161	80	22	156	200	14	G3/4"	G3/4"	G3/8"	

## 2BV6-070/071 外形尺寸图 / 2BV6 Series Dimension Drawing

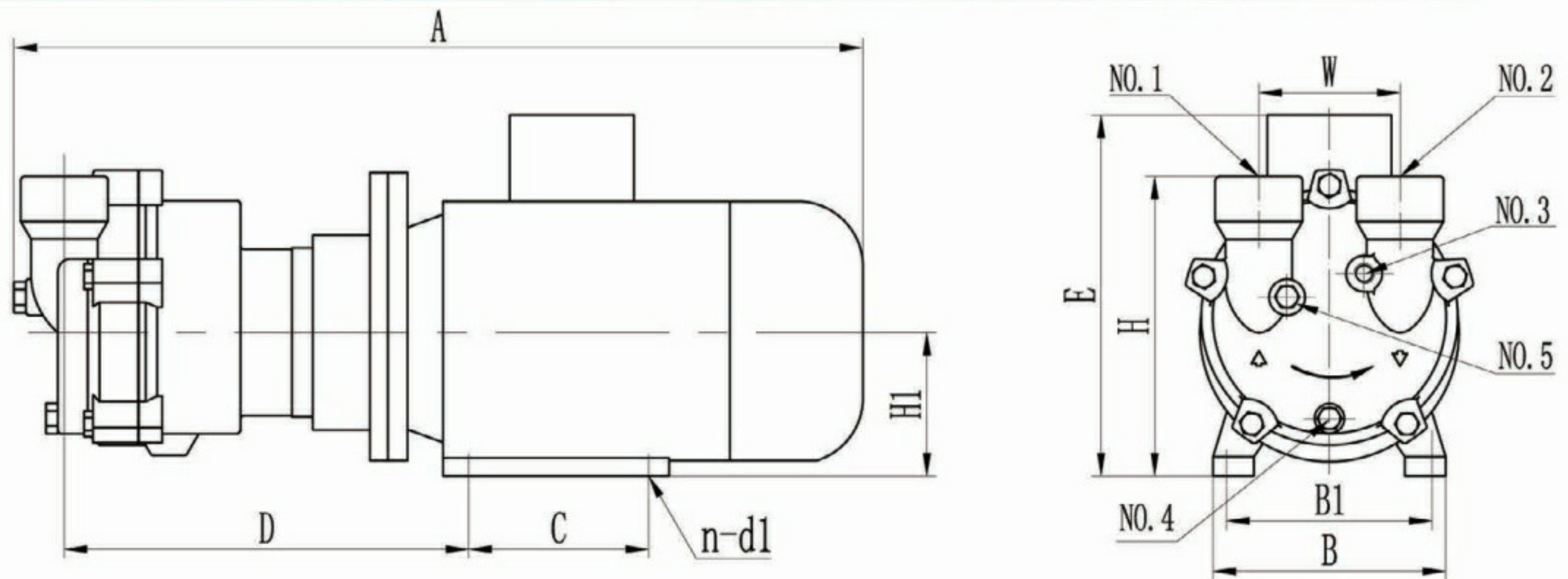

No.1 排气口 discharge port No.2 进气口 suction port No.3 供水口 water supply No.4 放水口 water outlet No.5 气蚀保护接口 anti-cavitation connection

型号	A	B	B1	C	D	E	H	H1
2BV6-070	680	200	160	140	315	325	234	100
2BV6-071	707	245	190	140	329	420	246	112
型号	W	n	d1	No. 1	No. 2	No. 3	No. 4	No. 5
2BV6-070	110	4	12	G1 1/2"	G1 1/2"	G3/8 "	G1/4 "	G3/8 "
2BV6-071	110	4	12	G1 1/2"	G1 1/2"	G3/8 "	G1/4 "	G3/8 "

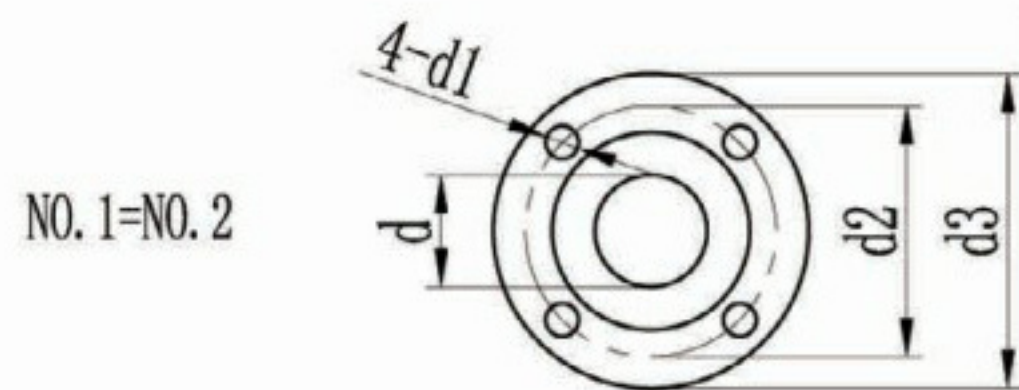
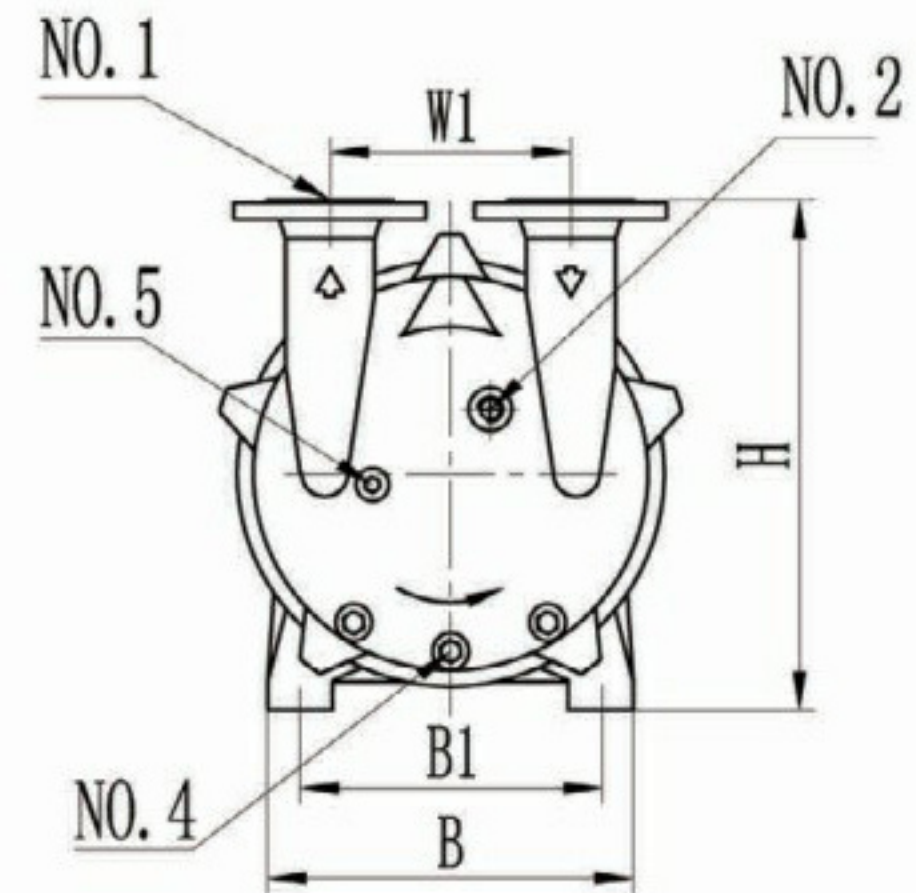
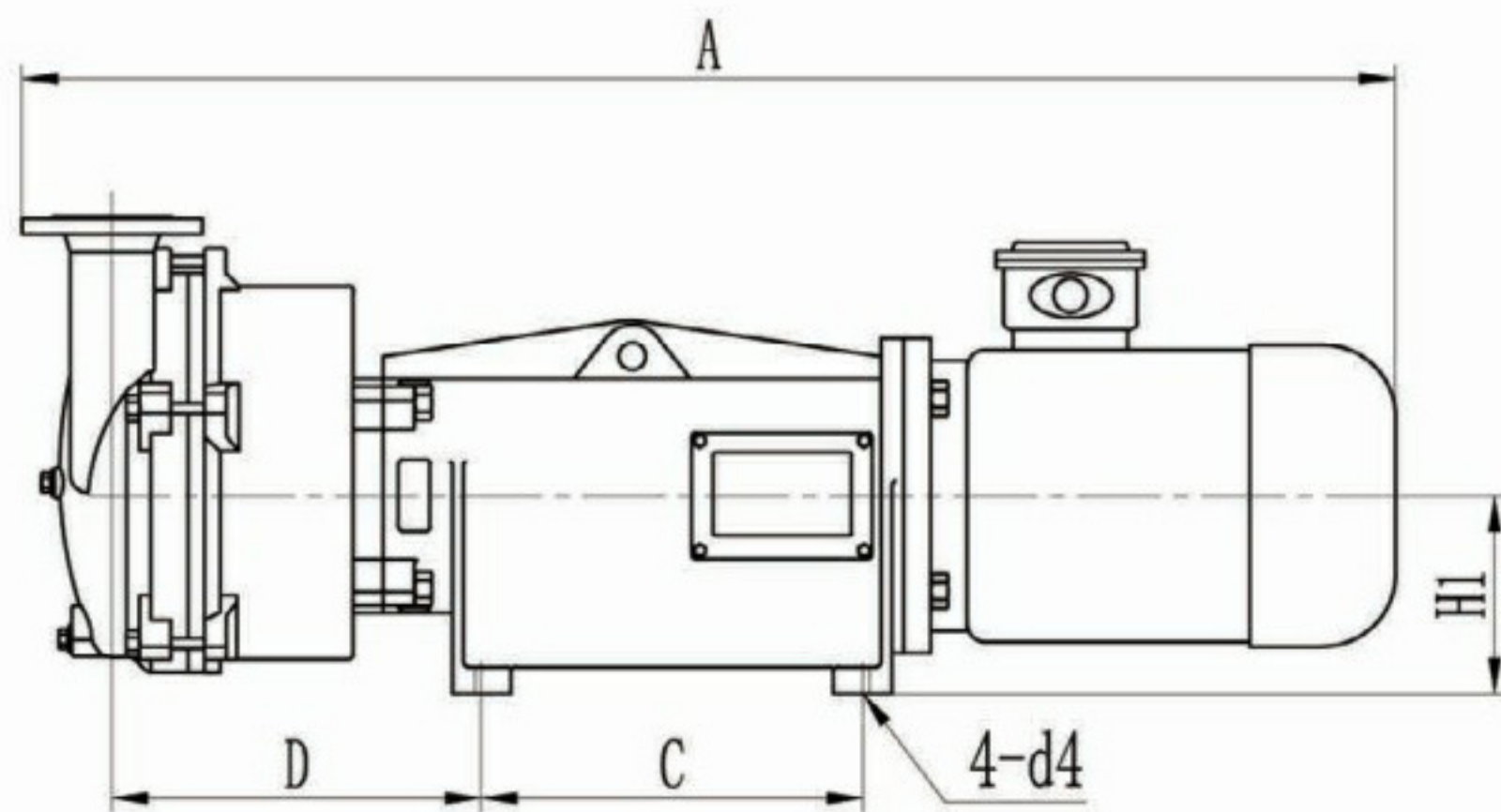

## 2BV6 系列外形尺寸图 / 2BV6 Series Dimension Drawing

No.1 排气口 discharge port  
 No.2 进气口 suction port  
 No.3 供水口 water supply  
 No.4 放水口 water outlet  
 No.5 气蚀保护接口 anti-cavitation connection

型号	A	B	B1	C	D	H	H1	W
2BV6-060	631	200	175	135	186	211	104	110
2BV6-061	688	200	175	135	217	211	104	110
2BV6-110	1043	340	252	248	281	383	163	180
2BV6-111	1216	340	290	325	332	406	185	180
2BV6-121	1264	382	290	325	349	420	185	200
2BV6-131	1455	390	316	417	351	531	220	200
2BV6-161	1615	480	316	417	409	521	220	200
型号	d	d1	d2	d3	d4	No. 3	No. 4	No. 5
2BV6-060	G1"	-----	-----	-----	12	G3/8 "	G3/8 "	G1/4 "
2BV6-061	G1"	-----	-----	-----	12	G3/8 "	G3/8 "	G1/4 "
2BV6-110	50	19	123	160	13	G3/8 "	G3/8 "	G1/2 "
2BV6-111	50	19	123	160	14	G3/8 "	G3/8 "	G1/2 "
2BV6-121	65	19	145	182	11	G3/8 "	G3/8 "	G3/4 "
2BV6-131	65	19	145	182	14	G3/8 "	G3/8 "	G3/4 "
2BV6-161	80	22	156	200	11	G3/4 "	G3/8 "	G3/4 "